



**FT 360 Functional Trainer**  
**Owner's and Service Manual**  
Strength Systems  
Part Number 59100





**FT 360 Functional Trainer  
Owner's and Service Manual  
Strength Systems  
Part Number 59100**

**DISCLAIMER:** Cybex International, Inc., makes no representations or warranties regarding the contents of this manual. We reserve the right to revise this document at any time or to make changes to the product described within it without notice or obligation to notify any person of such revisions or changes.

© Copyright 2000, 2001, 2002, 2003, 2004 Cybex International, Inc. All rights reserved.

Printed in the United States of America.

10 Trotter Drive Medway, MA 02053 • 508-533-4300 • FAX 508-533-5183

www.cybexinternational.com • Techhelp@cybexintl.com • techpubs@cybexintl.com • 59100 • March 2004



# Table of Contents

## i Table of Contents

### 1 Safety

Safety . . . . .	1-1
Warning/Caution Decals . . . . .	1-2
Regular Maintenance Activities . . . . .	1-7
Using Proper Form . . . . .	1-7

### 2 Technical Specifications

General Specifications . . . . .	2-1
Machine Specifications . . . . .	2-4

### 3 General Exercise Guidelines

Training Suggestions . . . . .	3-1
Glossary . . . . .	3-2
Exercise Charts	

### 4 Exercises

FT 360 Overview . . . . .	4-2
Adjustment and Safety . . . . .	4-2
Weight Stack and Effective Resistance . . . . .	4-2
Exercise Opportunities . . . . .	4-3
Lateral Step . . . . .	4-4
Overhead Squat . . . . .	4-4
Single Leg Squat . . . . .	4-5
Split Squat Press . . . . .	4-5
Hip Extension . . . . .	4-6
Hip Flexion . . . . .	4-6
Lunge Adduction . . . . .	4-7
Shoulder Adduction . . . . .	4-8
Chest Press . . . . .	4-9
Standing Chest Press . . . . .	4-9
Back and Shoulder Extension . . . . .	4-10
Shoulder Abduction . . . . .	4-10
Lat Pulldown . . . . .	4-11
Row . . . . .	4-11
Standing Overhead Press . . . . .	4-12
Push Pull . . . . .	4-12
Tricep Extension . . . . .	4-13

### 5 Customer Service

Contacting Service . . . . .	5-1
Ordering Parts . . . . .	5-1
RMA . . . . .	5-2
Damaged Parts . . . . .	5-3
Cybex Limited Warranty . . . . .	5-5

### 6 Assembly

FT 360 Diagram . . . . .	6-1
Tools Required . . . . .	6-2
Unpacking . . . . .	6-2
Installing Foot Pads . . . . .	6-4
Installing Snap Links . . . . .	6-5
Installing Weight Stack . . . . .	6-6
Installing Shroud . . . . .	6-13
Final Assembly . . . . .	6-14

### 7 Maintenance

Daily Procedures . . . . .	7-2
Weekly Procedures . . . . .	7-4
Yearly Procedures . . . . .	7-5
“As Required” Procedures . . . . .	7-5
Weight Stack Cable Adjustment . . . . .	7-6
Arm Cable Adjustment . . . . .	7-7

### 8 Service

Parts Lists and Diagrams . . . . .	8-1
------------------------------------	-----



# 1 - Safety

## Safety

Read the Owner's Manual carefully before assembling, servicing or using the equipment.

It is the responsibility of the facility owner and/or owner of the equipment to instruct users on proper operation of the equipment and review all labels.

***! WARNING: Serious injury could occur if these safety precautions are not observed:***

### User Safety Precautions

- Obtain a medical exam prior to beginning an exercise program.
- Read all warnings and obtain proper instruction on use of the machine prior to using.
- Keep body and clothing free from and clear of all moving parts.
- Inspect machine prior to use. **DO NOT** use if it appears damaged or inoperable.
- **DO NOT** attempt to fix a broken or jammed machine. Notify floor staff.
- Use the machine only for the intended use. **DO NOT** modify the machine.
- Be sure that the weight pin is completely inserted. Use only the pin provided by the manufacturer. If unsure seek assistance.
- Never pin the weights in an elevated position. **DO NOT** use the machine if found in this condition. Seek assistance from floor staff.
- Children must not be allowed near this machine. Teenagers must be supervised.
- **DO NOT** use if guards are missing or damaged.
- **DO NOT** use dumbbells or other incremental weights, except those provided by the manufacturer.
- Inspect all cables and belts and connections prior to use. **DO NOT** use if any components are worn, frayed, or damaged.
- **DO NOT** remove this label. Replace if damaged.
- Stop exercising if you feel faint, dizzy or experience pain at any time while exercising and consult your physician.

## Facility Safety Precautions

- Read the Owner's Manual carefully before assembling, servicing or using the equipment.
- Securely anchor each machine to the floor using the anchor holes provided in each machine.

**NOTE:** *Cybox is not responsible for the actual anchoring of equipment. Consult with a professional contractor.*

**NOTE:** *Use fasteners having a minimum of 500 lbs. tensile capacity (3/8" grade 2 bolts or better).*

**NOTE:** *If legs/frame does not contact surface, DO NOT pull down with anchors. Shim any leg or frame not in contact with surface using flat washers.*

- Make sure that each machine is set up and operated on a solid level surface. **Do not install equipment on an uneven surface.**
- Make sure that all users are properly trained on how to use the equipment.
- Make sure there is enough room for safe access and operation of the equipment.
- Perform regular maintenance checks on the equipment. Also pay close attention to all areas most susceptible to wear, including (but not limited to) cables, pulleys, belts and grips.
- Immediately replace worn or damaged components. If unable to immediately replace worn or damaged components then remove from service until the repair is made.
- Use only Cybox supplied components to maintain/repair the equipment.
- Keep a repair log of all maintenance activities.
- Inspect all cables and belts and connections prior to use. **DO NOT** use if any components are worn, frayed, or damaged.

**NOTE:** *It is the sole responsibility of the user/owner or facility operator to ensure that regular maintenance is performed.*

### **Warning/Caution Decals**

Warning decals indicate a potentially hazardous situation, which, if not avoided, could result in death or serious injury.

Caution decals indicate a potentially hazardous situation, which, if not avoided, could result in minor or moderate injury.

The warning and caution decals are shown on the following page. The diagrams following the decals show where each decal is located.



<p><b>⚠ WARNING</b></p> <p><b>SERIOUS INJURY COULD OCCUR IF THESE PRECAUTIONS ARE NOT OBSERVED</b></p>	<ol style="list-style-type: none"> <li>1. Obtain a medical exam prior to beginning an exercise program.</li> <li>2. Read all warnings and obtain proper instruction on use of the machine prior to using.</li> <li>3. Keep body and clothing free from and clear of all moving parts.</li> <li>4. Inspect machine prior to use. DO NOT use if it appears damaged or inoperable.</li> <li>5. DO NOT attempt to fix a broken or jammed machine. Notify floor staff.</li> <li>6. Use the machine only for the intended use. DO NOT modify the machine.</li> <li>7. Be sure that the weight pin is completely inserted. Use only the pin provided by the manufacturer. If unsure seek assistance.</li> <li>8. Never pin the weights in an elevated position. DO NOT use the machine if found in this condition. Seek assistance from floor staff.</li> <li>9. Children must not be allowed near this machine. Teenagers must be supervised.</li> <li>10. DO NOT use if guards are missing or damaged.</li> <li>11. DO NOT use dumbbells or other incremental weights, except those provided by the manufacturer.</li> <li>12. Inspect all cables and belts and connections prior to use. DO NOT use if any components are worn, frayed, or damaged.</li> <li>13. DO NOT REMOVE THIS LABEL. REPLACE IF DAMAGED.</li> </ol> <p style="text-align: right;">4800-381 B</p>
--	--

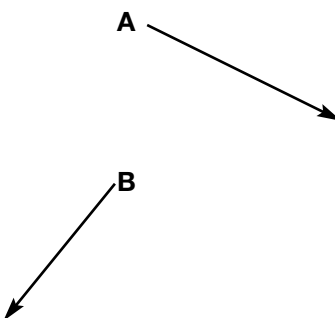

**⚠ WARNING**

**Notify floor staff if plates are elevated or jammed to avoid injury.**

02521 A

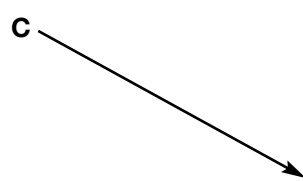

**⚠ CAUTION**

**Failure to correctly adjust could result in personal injury.**

**Always fully engage the detent pin before use to avoid injury.**

8500-025 B

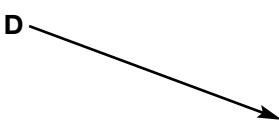

**⚠ WARNING**

**Arm will drop when knob is pulled. Support arm while adjusting arm position.**

**Be sure detent pin is fully engaged before use. Return arm to storage position when not in use.**

**Failure to do so could result in personal injury.**

8500-311 C

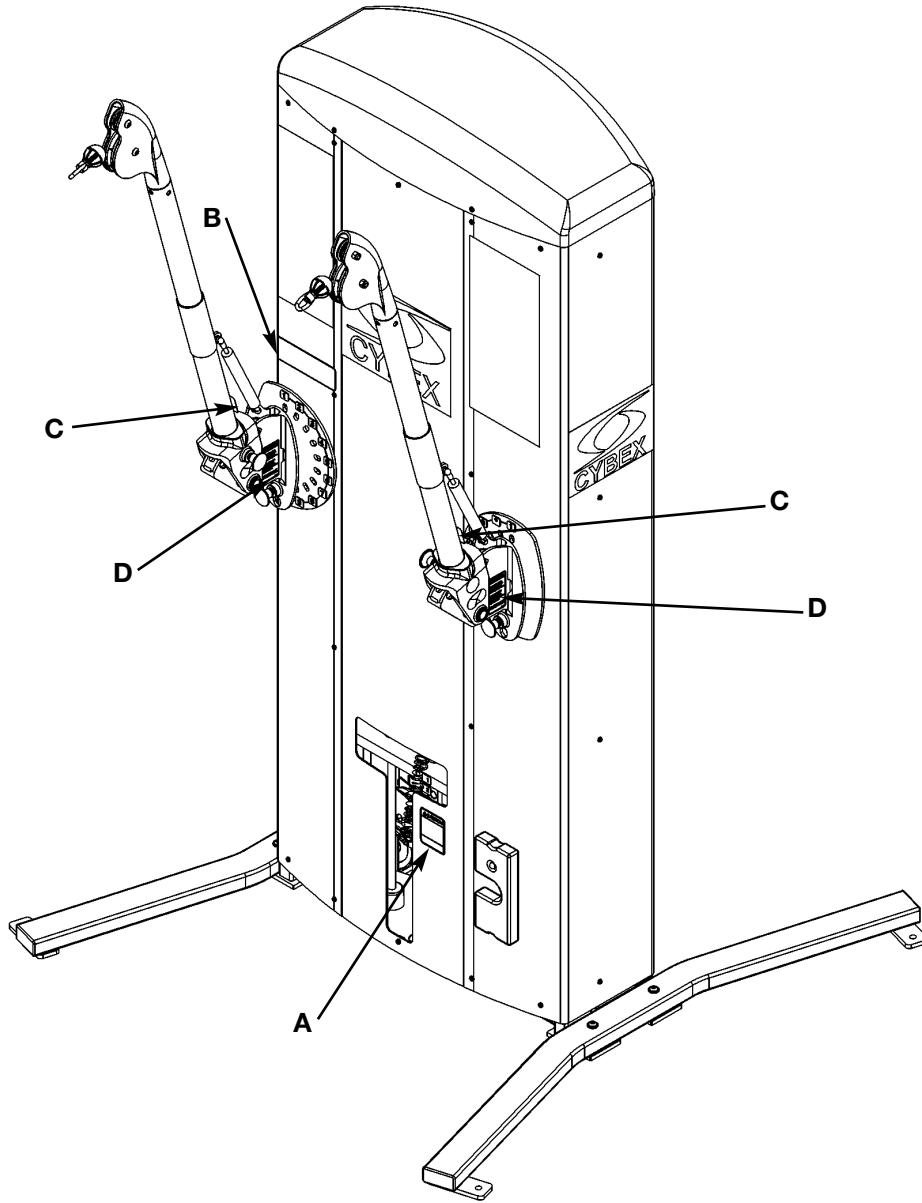

DESCRIPTION	PART NO.
A. Warning Decal.....	02521
B. Warning Decal .....	4800-381
C. Caution Decal .....	8500-025
D. Warning Decal.....	8500-311

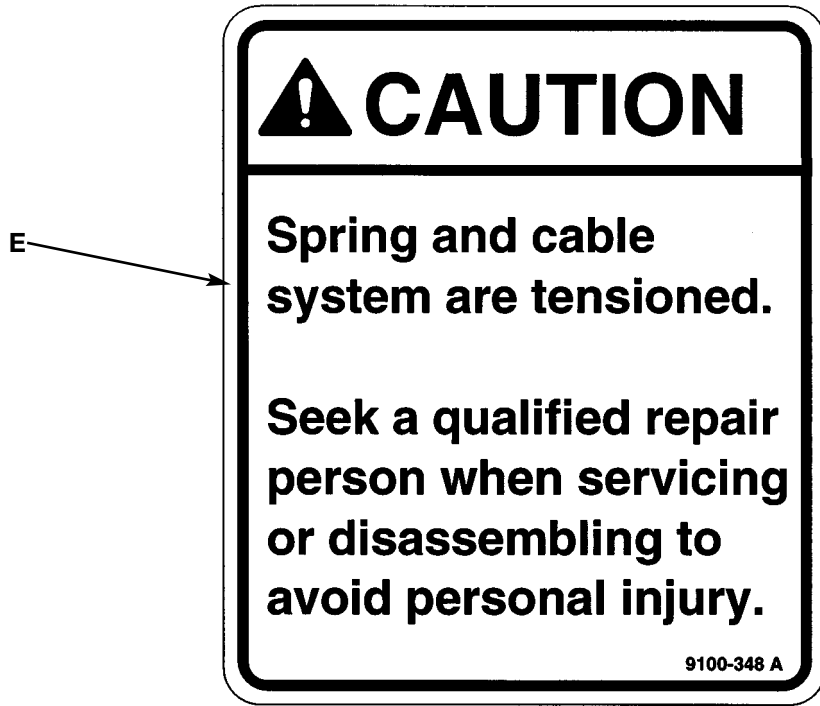

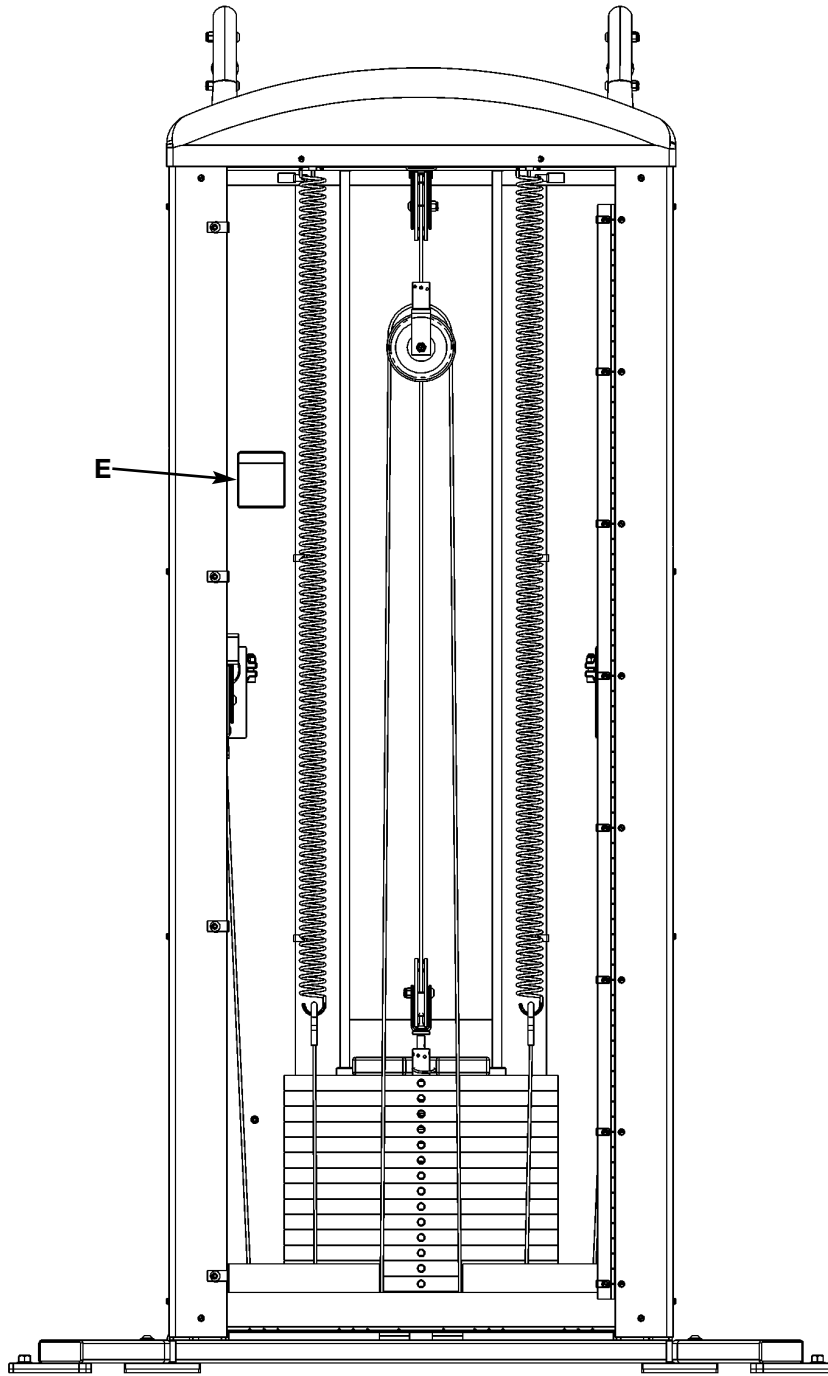

DESCRIPTION	PART NO.
E. Caution Decal .....	9100-348

### ***Regular Maintenance Activities***

Preventative maintenance activities must be performed to maintain normal operation of your equipment. Keeping a log sheet of all maintenance actions will assist you in staying current with all preventative maintenance activities. The preventative maintenance actions are described in detail in Chapter 5. Briefly, they include:

#### **Weekly**

1. Inspect all nuts and bolts for looseness. Tighten as required.
2. Inspect all cables for damage or wear (see Chapter 7). **Immediately discontinue use if a cable is worn or damaged.**
3. Check for worn handles, worn snap links, and worn warning labeling. Replace all worn parts immediately.
4. Inspect weight stacks for proper alignment and operation. Correct all improper alignment and operation issues immediately.
5. Lubricate guide rods using automotive engine oil only.

#### **Yearly**

1. Replace all cables at least annually.

#### **As Required**

1. Inspect grips and replace as necessary.

### ***Using Proper Form***

Before working out, read and understand the training suggestions listed in Chapter 3. See Chapter 4 for proper form during exercise.

***This page intentionally left blank***

## 2 - Technical Specifications

### General Specifications

#### Frame Finish

- Shall be made of mechanical quality 11 gauge and 16 gauge steel purchased in mill run quantities to assure the best consistency.
- Prior to applying finish, each part shall be put through a multi-stage wash to remove all oils and to chemically prepare the surface for maximum adhesion. After the wash, the frames shall be dried and coated with an Electrostatically applied powdercoat finish that shall be applied in powder form and then baked until cured.
- The finish shall be textured and very hard, assuring a scratch and chip resistant finish.

#### Weight Selection

- Weights are to be selected by using a high quality selector pin that completely penetrates the weight plate and locks in place to eliminate any chance of disengaging during use. The pin shall be attached to the weightstack with a plastic lanyard in order that the pin stays with the appropriate machine.

#### Weight Stacks Configuration

- All weight stacks shall have 4" x 18" x 1", 20 pound weights.

#### Weight Plates

- Shall be made of solid cold-rolled steel with wrinkle black powder coat finish.
- Guide rod holes shall be machined to a tolerance of  $\pm .006$  inches.

#### Top Weight Plate Bushings

- Low-friction bushings shall surround the guide rods for smooth gliding motion.

## **Pulleys**

- Shall use Dupont Corp. fiberglass-reinforced nylon 70G33 material, tensile strength rated at 22,500 PSI with 6203ZZ double sealed bearings dynamic load rated at 1600 lbs.
- Pulleys shall be 4.50 inches in diameter with a cable groove with a depth of .250 inches.

## **Swivel Pulley**

- Shall be molded from glass reinforced nylon, with a tensile breaking strength of at least 14,000 PSI.

## **Weight Transport**

- Shall be lubricated, 7 x 19, 1/8" galvanized steel, nylon coated aircraft cable with breaking strength rated at 2000 pounds.
- All cable ends shall be finished off with a swaged fitting with a breaking strength equal to the cable itself.

## **Weight Stack Guide Rods**

- Shall be solid ground and polished cold-drawn steel with minimum yield strength of 100,000 PSI with a hard chrome plated piston steel finish with an overall minimum accuracy of .010.

## **Weight Stack Suspension**

- Shall have heavy-duty neoprene bumpers with an 80-durometer rating under the weight stacks to reduce shock and vibration stresses to the frame and facility.

## **Frame Construction**

- Primarily 1 1/2 x 2" tubing with 11 gauge wall thickness, but different tubing sizes and wall thickness shall be used as required through engineering stress analysis.
- Shielding shall be 16 gauge wall thickness sheet metal.
- Fully welded frames for maximum structural integrity and minimum maintenance.
- All machining and welding will be done utilizing jigs and fixtures to insure highest quality and interchangeability of parts.

## **Pivot Adjustment**

- Shall be cast from 1020 steel and black powder coated.

## **Clevis**

- Shall be cast from 1020 steel and black powder coated.



### **Adjustment Plate**

- Shall be laser and plasma cut hot-rolled steel and nickel chromium electroplated.

### **Hardware**

- All 3/8" socket head cap screws shall be of grade 8 (or equivalent). All bolts shall be either chromed or zinc plated for additional corrosion resistance.

### **Adjustment Decals**

- High contrast Lexan decals shall be used for adjustment arms and weight stack to ensure maximum readability.

### **Instructional Placard**

- Shall provide step-by-step instructions and a picture to illustrate use.
- Placard shall indicate proper positioning, and clearly describe the correct use of machines.

### **Counter Balancing**

- Rotational counter balancing shall be accomplished by the use of a class 2 extension spring.
- Reach counterbalancing shall be accomplished by the use of a 13.35 inch, cylinder dampner.

### **Shroud**

- Front panel shall be made of shatter resistant PETG material and tinted Bronze #2370.

**Machine Specifications**

**FT 360 - Product No. 9100**

**Total Weight**

(includes weight stack)

787 lbs.

358 kg

**Weight Stack**

300 lbs.

136 kg

**Size**

inches - 113 W x 54 L x 90 H (maximum in use)

cm - 287 cm W x 137 cm L x 229 cm H

**NOTE:** A minimum of three feet clearance is required around the machine during exercise.

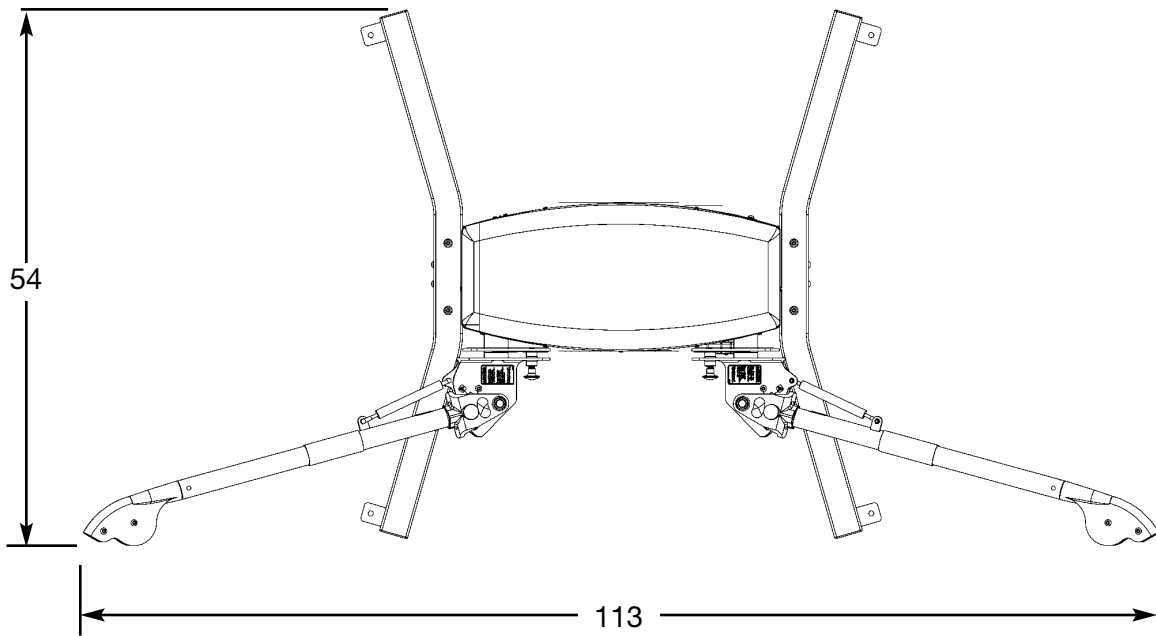

## 3 - General Exercise Guidelines

### Training Suggestions

#### Before you workout

Prior to starting a training program, get a complete physical exam to make sure your physician agrees that you are ready. Always warm-up your muscles before a workout. A 5-10 minute cardio warm-up followed by slow stretching (no bouncing) is recommended. Continue with a lighter set (50% of normal of intended exercises. Proper breathing is very important. Exhale during muscle exertion, and inhale while returning to the start position. Start your program conservatively. Choose weights you can easily lift in the first weeks. Always perform the full range of motion-unless you have an injury, then consult a professional trainer. Your Cybex dealer can help you find one. Know the terms? A “repetition” (rep) is defined as one complete movement through an exercise, returning to the start position. A “set” is a continuous series of reps. usually between 6-15.

#### During your workout

The number of reps. you perform in a set depends on your goal. To build muscle and strength, do fewer reps. (6-8) with heavier weight. To firm your muscles and build endurance, do more reps. (12-15) with lighter weight. Never “cheat” by shortening the range of motion, bouncing the weight, or shifting your posture. This may allow you to lift more weight, but it is dangerous and less effective. Catch your breath between sets, then continue. When “circuit training” move briskly to the next exercise; when doing multiple sets on one exercise, rest 45-90 seconds before the next set. Work up to three sets per exercise. When you can perform the desired reps and sets for any exercise, increase the weight by a half or full plate.

#### Designing your workout

Circuit training is a good way to start. This involves doing one set per exercise, then moving to the next exercise, pausing only briefly between them (to keep your heart and breath rate up) until completing a balanced “circuit” of 8-10 exercises for your entire body. Then repeat the circuit. After several weeks, you can move into multiple sets (3 in a row) per exercise if you choose. For both of these, exercise the complete body every other day, up to three times a week **Note:** *A full day's rest, plus proper nutrition and hydration are required for optimum muscle-building or toning.* Alternatively, work out half your body one day (e.g., the upper body) and the other half the following day (e.g. the lower body). To reduce muscle soreness, end each series of sets for a given muscle with a set of increased reps and lighter weights. At the end of your workout, cool down in a similar way to your warm-up.

**Glossary**

**Abduction** - movement away from the mid-line of the body.

**Acceleration** - the rate at which an object's velocity changes with time; that is the change of velocity divided by the time interval.

**Accuracy** - freedom from error. Degree of conformity of a measure to a standard or a true value.

**Action Line** -the direction of pull created by the fibers or tendons of the muscle at the point of application.

**Active Insufficiency** - a two joint muscle loses the ability to cross-bridge (generate force) due to full shortening over its greatest anatomical length and tension created in an opposing muscle (antagonist).

**Active Range of Motion** - the degree of motion that occurs between two adjacent segments through voluntary contraction of the agonist.

**Active Stabilization** - provided by an internal force. *Static* stabilization is provided through an isometric contraction where dynamic stabilization is a series of motions. *Dynamic* stabilizers maintain the relative positions of the segments, preventing undesirable or unnecessary motions due to external forces as well as artifacts of internal forces. May also refer to the concentric/eccentric contractions of a muscle acting in a force couple to produce motion while maintaining a relatively fixed axis of rotation.

**Adipose tissue** - fat tissue.

**Adduction** - movement towards the mid-line of the body.

**Agonist** - (prime mover) the muscle most involved in producing a movement.

**Aerobic** - utilizing oxygen.

**Aerobic Endurance** - the ability to persist in physical activities that rely heavily upon oxygen for energy production.

**Anabolic** - pertaining to the synthesis of complex substances from simpler substances, especially to the synthesis of body proteins from amino acids.

**Anaerobic** - without oxygen.

**Anaerobic Endurance** - the ability to persist in physical activities of short duration that require high rates of energy expenditure. These high rates of energy expenditure cannot be met solely by aerobic metabolism.

**Anthropometrics** - measurements and relationships of length and girth of body parts.

**Antagonist** - the muscle in opposition to the agonist.

**Anatomical Position** - standing erect, with feet and palms facing forward.

**Anatomical Pulley** - a bone or skeletal prominence that alters the direction of the pull of a muscle to increase the muscle's mechanical advantage.

**Anatomy** - geography, naming by orientation and/or apparent capability (non-functional).

**Anchor Points** - the points at which a load enters and exits the body and/or limb.

**Anterior** - anatomical term meaning towards the front. Same as ventral.

**Assistant Mover** - a muscle that is less effective at performing a specified motion, but does have a small degree of mechanical ability to help the prime mover. There are many borderline cases.

**Atrophy** - reduction in size of cells and tissues.

**Axis of Rotation** - imaginary line or point which an object rotates.

**Bilateral** - refers to both sides.

**Biocomotion** - a perspective/description of the human body and its mechanics based upon locomotion. All animals with legs (regardless of numbers) move with the same mechanics. Gravity is the common denominator.

**Biomechanics** - analysis of the load placed on a joint by both the muscle and resistance. Anatomy, Kinesiology, and Physics = Engineering.

**Body Composition** - the component parts of the body - mainly fat and fat-free weight.

**Calorie** - a unit of work or energy equal to the amount of heat required to raise the temperature of 1 g of water to 1 degree C.

**Cam** - a mechanical device used to vary leverage.

**Carbohydrate** - a chemical compound consisting of carbon, hydrogen and oxygen atoms in specified arrangements. Carbohydrates are major components of food such as bread, potatoes and rice.

**Cardiovascular** - pertaining to the heart and blood vessels.

**Cartilage** - there are several types. *Hyaline* cartilage is a relatively thin covering on the ends of many bones. It forms a smooth, resilient, low friction surface for the movement of one bone on another. Wedges of cartilage (fibrocartilage) called *menisci*, *disks* and *labrums* are to increase stability, provide shock absorption, and to facilitate motion in some joints.

**Center of Gravity** - the center of a body's mass. In the human body, it is the point which all parts are in balance with one another. The COG may be within the body, altered by the position of the body even to the point of being outside the body (pike position), or altered by the addition of load to specific body areas.

**Circumduction** - a circular movement permitted at ball and socket, condylar and saddle joints. Consists of flexion, abduction, extension and adduction in sequence.

**Circuit Training** - a conditioning program consisting of a number of exercises performed at "stations". Usually, a given exercise is performed at a station within a specified time; then the athlete moves to the next station, with its own particular exercise and specified time, then to the next station, and so on.

**Closed Chain Kinetic Exercise** - a series of rigid links interconnected by a series of pincentered joints. These are constructed so that motion at one joint will produce motion at all the joints in the system. Produces greater mechanical efficiency at the risk of increased joint loading. Leg press, bench press.

**Close-Packed Position** - all synovial joints have a position where joint surfaces are maximally congruent and the ligaments and capsule are maximally taut.

**Collagen** - a fibrous protein that serves as the major component of ligaments and tendons.

**Compression** - two forces acting along the same line towards each other that constitute a compressive load or compressive stress.

**Concentric action** - contraction of a muscle resulting in shortening of the muscle.

**Connective Tissue** - comprised of mostly the proteins collagen and elastin with water; includes tendons, ligaments, bursae, cartilage, disks, menisci, fascia and bone.

**Cross-bridge** - the connection and intertwining of the actin and myosin filaments in a myofibril relative to a muscular contraction.

**Curvilinear Motion** - the frequently occurring combination of rotatory and translatory motions.

**Distraction** - two forces acting along the same line and in opposite directions, they constitute a distractive, tensile load or tensile stress.

**Diathrodial Joint** - ball and socket joint.

**Distal** - furthest from the attached end of the limb; away from the body.

**Dorsal** - pertaining to the back; opposite of ventral, palmar or plantar.

**Dorsiflexion** - movement of the foot up in the sagittal plane; movement toward the leg.

**Eccentric** - muscle action in which tension is developed in the muscle while it is lengthening. *Negative* work is performed.

**Eccentric Action** - a muscle contraction incapable of overcoming the resistance imposed; the overall muscle length increases.

**Endurance**- the ability to persist in performing some physical activity.

**Energy** - the capacity to perform work.

**Energy (kinetic)** - energy associated with motion.

**Energy (potential)** - energy by virtue of position.

**Energy System** - one of three metabolic systems involving a series of chemical reactions resulting in the formation of waste products and the manufacture of ATP.

**Eversion** - movement of the sole of the foot outward; opposite of inversion.

**Extension** - movement at a joint, bringing two parts into or towards a straight line, increasing the angle of the joint. Returning to anatomical position from a position of flexion in the sagittal plane.

**External Force** - a push or pull on the body that arises from a source outside the body.

**External Rotation** - movement of the anterior surface of a segment away from the mid-line; also termed lateral rotation.

**Fast-twitch Fibers** - skeletal muscle fibers most active in short-duration, intensive exercise, e.g., in sprints and jumps.

**Fatigue** - the inability to maintain a given level of physical performance.

**Flexibility** - the range of movement of a specific joint or group of joints, influenced by the associated bones and bony structures, muscles, tendons and ligaments.

**Flexion** - movement about a joint in which bones on either side of the joint are brought closer together, decreasing the angle of the joint. Joint movement away from anatomical position, occurring within the sagittal plane.

**Foot-pound** - the work required to move one pound of resistance one foot in distance.

**Force** - an interaction between two objects, in the form of a push or pull, that may or may not produce motion,  $\text{Force} = \text{mass} \times \text{acceleration}$ .

**Force Angle** - (FA) the angle between the action line and the lever, on the side of the joint axis.

**Force Couple** - concentric/eccentric contractions of opposing muscles acting to produce motion while maintaining a relatively fixed axis of rotation.

**Frontal Plane** - (coronal) imaginary line that divides the body into anterior and posterior halves; lies at a right angle to the sagittal plane.

**Fulcrum** - the support on which a lever rotates in moving or lifting.

**Hyperextension** - continuation of the movement of extension past the neutral position.

**Hypertrophy** - increased cell size leading to increased tissue size.

**Impulse** - the change in momentum.

**Inertia** - the tendency of a body to remain at rest or continue in motion unless disturbed by an external force.

**Inferior** - a lower position upon or within the body.

**Insertion** - the more distal attachment site of a muscle. The movable part or attachment of a muscle as opposed to origin.

**Intermittent Work** - work sessions interrupted by rest sessions.

**Internal Forces** - act on the body and arise from sources within the human body.

**Inversion** - moving the sole of the foot inward. Opposite of eversion.

**Isokinetic** - action in which the rate of movement is constantly maintained through a specific range of motion even though maximal force is exerted.

**Isokinetic Contraction** - a muscular contraction through a range of motion at a constant velocity.

**Isometric** - a contraction in which movement is produced but no movement occurs.

**Isometric (static) Contraction** - a muscular contraction in which there is no change in the angle of the involved joint(s) and little or no change in the length of the contracting muscle.

**Isotonic** - a contraction in which movement is produced.

**Medial Rotation** - movement around an axis and toward the mid-line of the body. Also termed internal rotation.

**Medial** - aspect nearest the mid-line of the body; pertaining to the center. Opposite of lateral.

**Metabolism** - the sum total of the chemical changes or reactions occurring in the body.



**Moment Arm** - (MA) the shortest distance between the action line and the joint axis.

**Momentum** - determined by mass x velocity. Will remain constant unless the object is acted upon by another force.

**Muscle Contraction** - shortening of a muscle and/or development of tension in a muscle.

**Muscular Endurance** - the ability of a muscle or muscle group to perform repeated contractions against a light load for an extended period of time.

**Neutral** - a point between the two extremes of a joint's range of motion.

**Obesity** - excess body fat.

**Open Kinematic Chain** - the ends of the limbs are free to move without causing motion at another joint. Open chain motions are not predictable because the joints may function either independently or in unison. Less mechanically efficient, therefore more stress is placed upon muscular tissue.

**Origin** - attachment of a muscle that remains relatively fixed during muscular contraction.

**Overload** - to exercise a muscle or muscle group against resistance greater than that which is normally encountered. The resistance (load) can be maximal or near-maximal.

**Passive Insufficiency** - a two-joint muscle loses the ability to cross-bridge (generate force) due to full lengthening over its greatest anatomical length due to force created in an opposing muscle.

**Passive Stabilization** - due to noncontractile components. *Internal* stabilization is created by connective tissue (muscular support is not provided anatomically or physiologically) and *external* stabilization is provided by a bench or brace.

**Plane of Motion** - a two-dimensional flat surface running through an object. Motion occurs in the plane or parallel to the plane.

**Plantar** - anatomical term referring to the sole or bottom.

**Plantarflexion** - movement of the foot down in the sagittal plane; movement away from the leg.

**Posterior** - anatomical term meaning toward the back. Opposite of anterior.

**Potential Energy** - energy by virtue of position.

**Power** - the product of force and velocity. Work divided by time.

**Prime Mover** - (agonist) a muscle that is mechanically optimal to produce a specific motion at a joint. There can be more than one prime mover for a particular motion, and a specific muscle can be a prime mover for more than one motion at a joint.

**Progressive Resistance** - overloading a muscle or muscle group consistently throughout the duration of a weight-resistance program.

**Pronation** - a triplanar motion at the subtalar joint consisting of abduction, depression and eversion, resulting in lowering of the longitudinal arch of the foot. Position of the forearm with the palm facing down.

**Protein** - a basic foodstuff containing amino acids.

**Proximal** - towards the attached end of the limb or origin.

**Range of Motion** - the amount of motion available to a joint within the anatomical limits of the joint structure. Can be classified as *Passive* (movement produced via a force outside the limb), *Active* (movement produced by muscles within the limb) or *Resisted* (movement challenged under additional load). The amount of resistance will affect the range of motion with direct proportion.

**Reciprocal Inhibition** - contraction of agonist causes relaxation of antagonist.

**Reliability** - the extent to which an experiment, test or measuring procedure yields the same results on repeated trials. Also known as reproducibility or repeatability.

**Repetition Maximum (RM)** - the maximum load that a muscle or muscle group can lift in a given number of repetitions before fatiguing. For example, an eight-RM load is the maximum load that can be lifted eight times.

**Repositioners** - muscles that lift the extremity and move it to a new location allowing the prime movers to again accept load or propel.

**Response** - a sudden temporary adjustment in physiological function brought on by a single exposure to exercise, e.g., the rise in heart rate associated with an exercise bout.

**Rotary Motion** - (radial or angular) the movement of an object around a fixed axis in a curved path.

**S.A.I.D. Principle** - Specific Adaptation to Imposed Demand. A muscle will gain strength in the specific ranges of motion and speeds in which it is trained.

**Sagittal Plane** - Imaginary line that divides the body, or any of its parts, into right and left sections.

**Scoliosis** - a lateral curvature of the vertebral column, usually in the thoracic area.

**Secondary Joint** - hinge joints that have a singular function (elbow/knee). Muscles are situated on either side of these joints in virtual, if not real, pairings.

**Set** - in an interval training program, a group of work and relief intervals. In weight lifting, the number of repetitions performed consecutively without resting.

**Shear** - two parallel forces applied in opposite directions that are not in line with each other constitute a shearing load or stress. The site of muscular attachment is the axis around which the forces of shear develop. This becomes the “force axis” as opposed to the anatomical axis.

**Shunt Muscle** - directs the greater part of its contractile force along the bone it is moving (creating greater force towards compression/stabilization). The brachioradialis is a shunt during an arm curl.

**Skeletal Muscle** - muscle controlling skeletal movement that is normally under voluntary control.

**Skewing** - the result of a vector shift through a limb or system.

**Sliding Filament Theory** - a muscle shortens or lengthens because the thick and thin myofibrils slide past one another without the filaments changing length.

**Slow-twitch Fibers** - skeletal muscle fibers characterized by relatively slow contraction times and great capacity for the aerobic production of adenosine triphosphate.

**Sprain** - the permanent deformation of the structure due to excessive or prolonged stress/strain.

**Spurt Muscle** - directs the greater part of its force across the bone it is moving rather than along it (creating greater effort towards motion). The biceps is a spurt during an arm curl.

**Stabilizer** - a muscle that steadies or supports a joint in order that another active muscle may have a firm base upon which to pull.

**Static contraction** - a muscular contraction that does not involve changes in the angle of the joint(s) involved.

**Steady state** - that state of physiological stability wherein the energy demands of the body can be met relatively easily for a prolonged period of time.

**Strain** - the deformation of the structure as the result of stress.

**Strength** - the ability to exert muscular force briefly.

**Stress** - the force created within a structure when placed under load.

**Submaximal exercise** - usually exercise at less than maximal intensity, but may also refer to exercise of less than maximal duration.

**Superior** - a higher position upon or within the body.

**Synergist** - occurs during the action of two muscles, both of which have a common joint action and each of which has a second action that is antagonistic or opposing to the other. True synergy is simply the stabilization of one muscle to prevent any action in one of the joints traversed by a multi-joint muscle.

**Synovial Fluid** - transparent, viscous lubricating fluid found in joint cavities, bursae and tendon sheaths.

**Tendons** - cords of dense fibrous tissue that connect muscle to bone.

**Tertiary Joint** - a complex joint structure (wrist/ankle-subtalar), designed for finely controlled movements.

**Torque** - the ability of a force to produce movement around an axis.

**Training** - a program of exercise designed to improve the skills and increase the energy capacities of an athlete for a particular event.

**Translatory Motion** - (linear) the movement of an object in a straight line.

**Unilateral** - refers to only one side.

**Validity** - the extent to which a measurement or information is relevant or meaningful; appropriate to the end in view and supported by objective truth.

**Vector** - an arrow which represents a force's point of application, action line or direction indicating pull or magnitude of force being exerted.

**Vector Shift** - the alteration of a load as it is transferred between the anchor points through a segment's kinematic chain.

**Velocity** - the rate at which an objects position changes with time; that is the total change in position divided by the total change in time:  $V=d/t$ .

**Weight** - the weight of an object is the gravitational force exerted on it by the earth.  $W=mg$ , where  $g$  = gravitational acceleration.

**Work** -  $W = Fd$ . The amount of work performed is equivalent to the force applied to an object times the distance the object is moved.











# 4 - Exercises

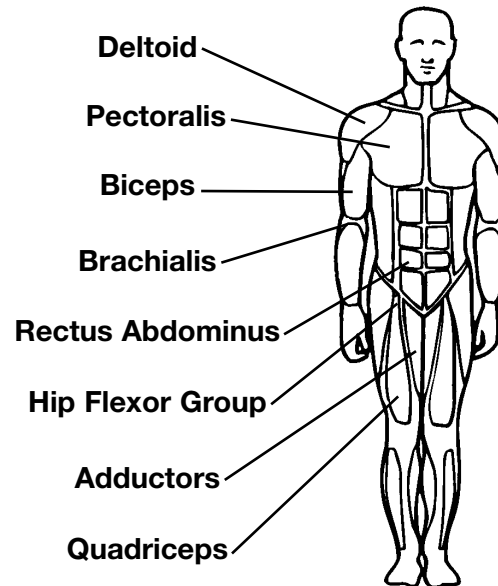
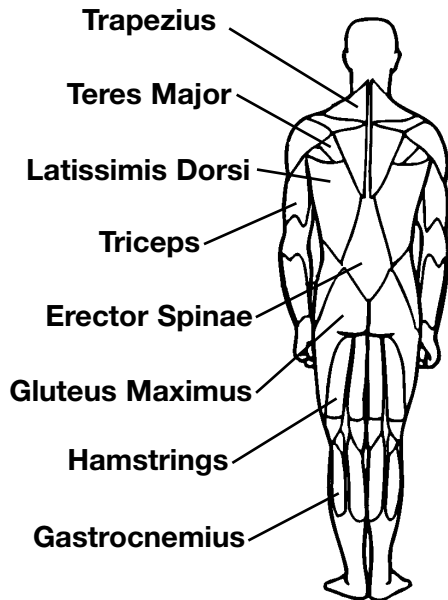
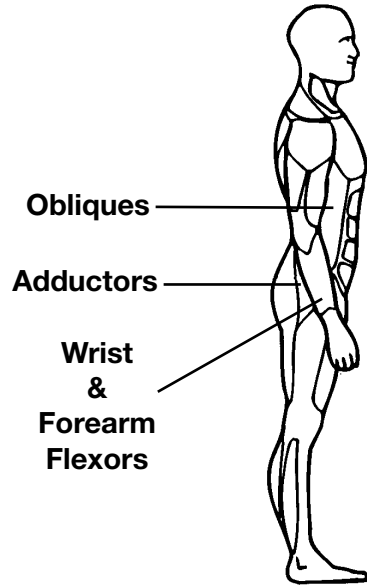

Read and understand all instructions and warnings prior to using equipment.

**NOTE:** See the general training suggestions in Chapter 3 and all of the safety related information located in Chapter 1.

### **FT 360 Overview**

The Cybox FT 360 Functional Trainer is an advanced training tool, allowing near infinite adjustability. This section will provide you with pertinent information for using the FT 360, including: adjustment and safety; weight stack and effective resistance; exercise opportunities.

### **Adjustment and Safety**

The arms on the FT 360 adjust in two planes of motion, offering the unique ability to truly fine-tune the path-of-motion. These planes of motion are composed of a “Rotational” pattern and a “Reach” pattern. The available rotation totals 180 degrees of motion. Providing 10-positions, numbered 1-10, separated in 20-degree increments. The available reach is a total of 45 degrees of motion, with 3 positions of adjustment separated in 15-degree increments. These adjustments are lettered A-C, which can be manipulated allowing modification for user height or desired range-of-motion.

Each arm is counterbalanced in both directions, providing ease of adjustment and a reliable safety profile. A grip is located on the arm as a reference point for holding the arm during adjustment.

**NOTE:** It is recommended that the arm be controlled during adjustment for optimal safety. Additionally, ensure that the path that the arm moves in during adjustment is clear of persons and other objects.

### **Weight Stack and Effective Resistance**

One 300 lb. weight stack provides the resistance for both exercise arms. Each plate is 20 lbs., allowing 15 adjustments. Additionally, a 10 lb. drop-on increment weight is provided to fine-tune the resistance. The high-mass short-travel weight stack decreases momentum and inertia, making the FT 360 appropriate for rehabilitation and sport performance training.

The cabling mechanism in the FT 360 is unique allowing for either unilateral or bilateral exercise. The effective resistance when working with each arm thus becomes one-fourth the weight of each weight plate. For instance, if working with only the top-plate, the user will experience only 5 lbs. (4:1) when using only one arm and 10 lbs. (2:1) when working with the arms together. The increment weight effectively becomes 2.5 lbs. with one arm and 5 lbs. with both arms.

**! CAUTION:** Make sure weight stack pin is fully inserted prior to use.

***Exercise Opportunities***

The combination of two-plane adjustability and a 4:1/2:1 weight stack design, create an exercise system capable of exceptional application. This system provides an ideal platform from which to perform rehabilitative, sport specific, human performance, and traditional exercises.

The remainder of this section describes specific exercises that can be performed with the Cybex FT 360 Functional Trainer. Each of the Exercises can be modified to conform to the range-of-motion of the user by manipulating either the rotational or reach adjustments.

### ***Lateral Step***

Arm Positioning: 5-B

1. Position the hip harness around your waist, attaching with clip positioned at side of body.
2. Stand in a semi-squat position so that hips and knees are flexed approximately 45 degrees.
3. Initiate with a motion that pushes with the planted foot, stepping away from the cable, landing on the driving foot.
4. Continue this lateral progression, maintaining this semi-squat position.
5. Return to the starting position and repeat, then perform with the opposite leg.



### ***Overhead Squat***

Arm Positioning: 2-B

1. Stand facing away from the machine, positioning your arms overhead.
2. Initiate the movement with a squat motion, maintaining your arms extended overhead throughout the motion.
3. Keep your torso stabilized and maintain proper squat technique throughout the motion.
4. Your range of motion will be determined by how far you can squat, without rounding your spine.
5. Return to the starting position and repeat.



### Single Leg Squat

Arm Positioning: 5-B

1. Position the hip harness around your waist, attaching with clip positioned at front of body.
2. Begin in a single leg stance facing swivel pulley, arms positioned on hips or out to sides for balance.
3. Perform a squatting motion keeping torso stabilized.
4. Your range of motion will be determined by your ability to maintain balance and flexibility.
5. Return to the starting position and repeat, then perform motion on the opposite leg.

**NOTE:** The padded hip strap allows the resistance to be loaded directly at the hips, keeping the hands free. The exercise may also be performed holding the soft crossover handles overhead (10-C) or from below (1-C), which provides an added rotation resistance to the torso.



### Split Squat Press

Arm Positioning: 1-B

1. Stand facing away from the machine, positioning your feet staggered and holding the grips at shoulder level.
2. Initiate the movement with a hip flexion motion downward.
3. Maintain torso stabilization and return to standing while simultaneously pressing overhead.
4. Return to the starting position and repeat.

**NOTE:** Ensure that foot positioning is sufficient, so that forward knee does not move past toes.

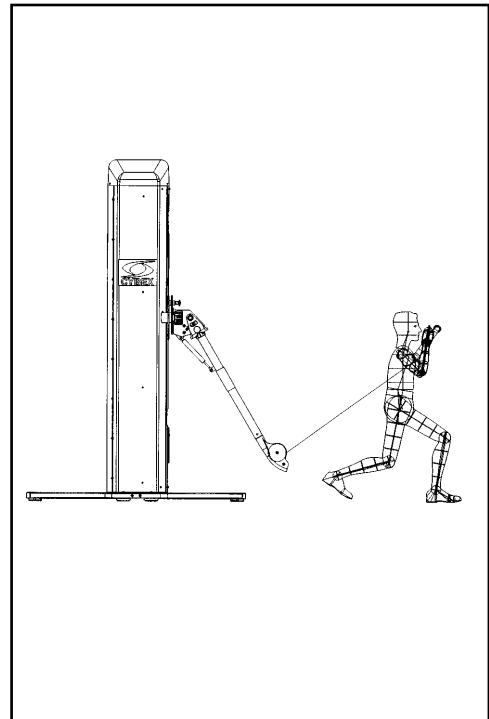

### **Hip Extension**

Arm Positioning: 1-A

1. Attach the ankle strap around your ankle, with clip positioned towards the front.
2. Stand facing the machine with your support leg bent slightly at the knee.
3. Initiate the movement with a pressing motion backward using the driving foot, about 20 degrees.
4. Maintain torso stabilization and focus on hip musculature, without allowing your back to excessively arch for increased motion.
5. Return to the starting position and repeat, then perform with the opposite leg.



### **Hip Flexion**

Arm Positioning: 2-A

1. Attach the ankle strap around your ankle, with clip positioned towards the back.
2. Stand at 90 degrees to the machine, then adjust the other machine arm to a height which allows it to be utilized for balance.
3. Maintain your support leg slightly bent at the knee and initiate the movement with a lifting motion using the driving foot.
4. Lift your leg to no more than 45 degrees, maintaining torso stabilization and focusing on hip musculature.
5. Return to the starting position and repeat, then perform with the opposite leg.



***! CAUTION: Be sure to utilize the machine arm for balance only. Do not use the arm to support your body weight, which may result in machine damage or injury.***

## Lunge Adduction

Arm Positioning: 6-C

1. Begin in standing facing away from the machine. Position your arms level with the ground, out to sides and elbows slightly bent.
2. Initiate the movement with a lunge motion forward, while simultaneously performing an adduction (fly) motion at the shoulder.
3. Return to the starting position by pushing back with your forward foot and abducting (move out) your arms.
4. Repeat the motion, then perform with the opposite leg.

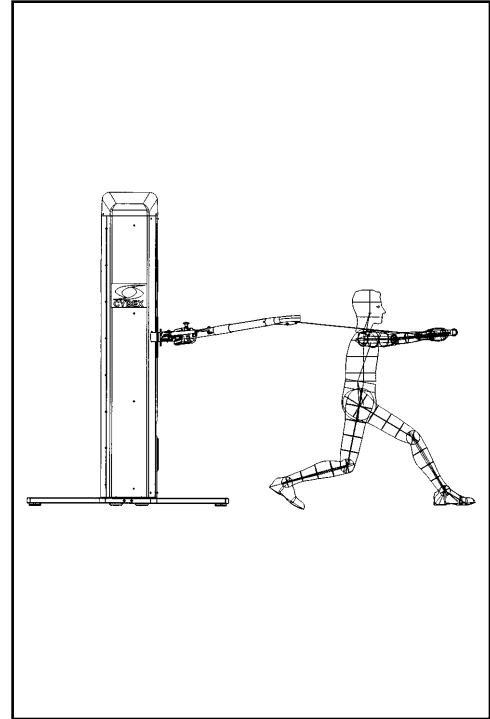

## Shoulder Adduction

Arm Positioning: 2-A

1. Stand at 45 degrees to the face of the machine with your feet apart and knees bent slightly.
2. Grasp the handle while keeping your arm straight and elbow slightly bent. Maintain this position throughout the exercise.
3. Draw the handle upwards and diagonally across your body and maintain torso musculature contracted throughout the motion.

**NOTE:** *Your range of motion has been exceeded when torso rotation occurs with continued motion.*

4. Return to starting position and repeat, then perform motion on the opposite side.

**NOTE:** *Exercise may be performed with the machine arm in various positions for numerous paths-of-motion. Altering your standing position can change the force curve for the motion dependent upon your goal.*





### Chest Press

Arm Positioning: 2-B

1. Set a bench in-between the arms and attach the soft crossover handles.
2. Position yourself on bench, aligning the arm-ends with your shoulders.
3. Position feet securely on the floor and your upper arms level with the ground, elbows bent 90 degrees.
4. Maintain proper shoulder positioning, chest-up and shoulders-back as you press the handles upward and together.
5. Return to the starting position and repeat.

**NOTE:** Bench angle can be adjusted to create various paths of motion. Machine Arms positioning may need (A-C) adjusting for proper alignment. Exercise may also be performed with the use of a stability ball for variety.



### Standing Chest Press

Arm Positioning: 7-C

1. Stand facing away from the machine, with your feet staggered and leaning forward slightly at hips for balance.
2. Position your upper arms level with the ground and elbows bent 90 degrees. This is the plane of motion to maintain throughout the exercise.
3. Maintain proper shoulder positioning, chest-up and shoulders-back as you press the handles out and together.
4. Return to the starting position and repeat.



### **Back and Shoulder Extension**

Arm Positioning: 1-A

1. Stand facing away from the machine with your hips flexed, back straight and arms at sides.
2. Begin the motion with back extension and then simultaneously raise handles up to the front.
3. Finishing the movement with your hands extended near eye level, maintain torso stabilization through the motion.
4. Return to the starting position and repeat.

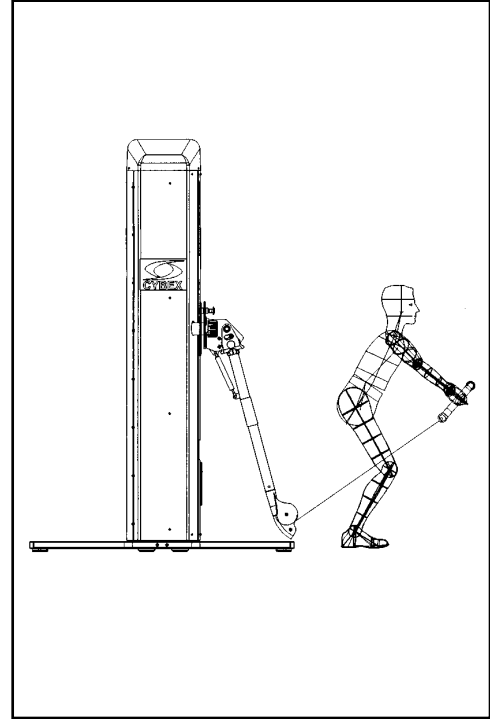

### **Shoulder Abduction**

Arm Positioning: 2-A

1. Stand at 45 degrees to the face of machine with your feet apart and knees bent slightly.
2. Reach down across your body, grasp the handle, while keeping your arm straight and elbow slightly bent.
3. Draw the handle upwards and diagonally across your body and maintain your torso musculature contracted throughout motion.

**NOTE:** *Your range of motion has been exceeded when torso rotation occurs with continued motion.*

4. Return to the starting position and repeat, then perform motion on the opposite side.

**NOTE:** *Exercise may be performed with the machine arm in various positions, for numerous paths-of-motion. Altering your standing position can change the force curve for the motion dependent upon goal.*



### Lat Pulldown

Arm Positioning: 9-A

1. Place a stability ball or bench in-between arms and sit facing the machine. Grasp the handles with your arms extended overhead.
2. Initiate the motion by drawing elbows out and downward towards your sides.
3. Maintain proper posture and shoulder positioning, keeping your chest-up and shoulders-back throughout the motion.
4. Return to the starting position and repeat.

**NOTE:** This exercise can also be performed in standing, pulling the handles either unilaterally or bilaterally down to the front. Multiple angles can be used for variety.



### Row

Arm Positioning: 1-A

1. Stand facing the machine in a slight squat position, leaning forward slightly at hips.
2. Grasp the handles and maintain your upper body in proper posture with torso stabilized. This will be your exercise position throughout the exercise.
3. Perform a row motion, either unilaterally or bilaterally, by drawing your elbows towards the back of your body.

**NOTE:** This motion may also be performed attempting to maintain the weight stack in an elevated position. This continuous row motion creates a different training stimulus for variety.



### Standing Overhead Press

Arm Positioning: 1-C

1. Stand facing away from the machine, grasp the crossover handles holding them at eye level.
2. Position yourself with knees slightly bent and torso stabilized. Maintain this position throughout the exercise.
3. With controlled movements perform an overhead pressing motion, without allowing your back to excessively arch.
4. Lower the handles to a position where the upper arms are approximately parallel to the ground. This is your ideal range of motion.
5. Return to the starting position and repeat.

**NOTE:** Exercise may also be performed while sitting on a stability ball or bench (Arm Positioning 2-A) for variety.



### Push Pull

Arm Positioning: 6-C

1. Stand at 90 degrees to the machine, positioning yourself with one arm extended and the other flexed 90 degrees.
2. Maintain your torso musculature contracted. Initiate the movement with a alternating push-pull motion; pulling one grip while pressing the other.

**NOTE:** Your lower body should not rotate during the motion. Your upper body should rotate slightly while performing rowing motion.

3. Repeat the motion, then perform in the opposite direction.

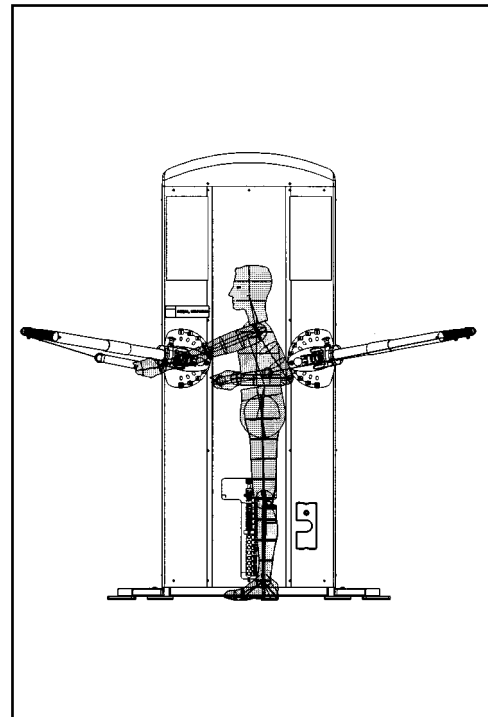

***Tricep Extension***

Arm Positioning: 9-C

1. Stand facing away from the machine, positioning your feet staggered and leaning forward slightly at the hips for balance.
2. Hold the grips with your arms raised shoulder level and elbows flexed 90 degrees. Maintain your upper arms level with the ground.
3. With palms facing forward, press the handles out extending your arms.
4. Return to the starting position and repeat.



*This page intentionally left blank*

## 5 - Customer Service

### Contacting Service

Hours of phone service are Monday through Friday from 8:00 a.m. to 6:00 p.m. Eastern Standard Time.

For Cybox customers living in the USA, contact Cybox Customer Service at **800-766-3211**. Your options at this number include:

- Press **63** to place a parts order or to check parts order status.
- Press **64** to speak to a technical support representative regarding troubleshooting or to schedule a field service call.
- Press **65** to check status of a repair order only and you have your RRM number.
- Press **66** to check status of a dispatched field service call and you have your inquiry number.
- Press **67** for service of a medical or isokinetic product.
- Press **0** to go to the Cybox operator.

For Cybox customers living outside the USA, contact Cybox Customer Service at **508-533-4300** or fax **508-533-5183**.

Order parts and find information on the web at [www.eCybox.com](http://www.eCybox.com) or by e-mail at [techhelp@cyboxintl.com](mailto:techhelp@cyboxintl.com).

### Ordering Parts

Visit [eCybox.com](http://eCybox.com) to shop for parts online or fax your order to **508-533-5183**.

To speak with a customer service representative, call **800-766-3211** (for customers living within the USA) or **508-533-4300** (for customers outside the USA). You may also contact us through email at [techhelp@cyboxintl.com](mailto:techhelp@cyboxintl.com)

Having the following information ready when calling will assist our Cybox representatives in serving you:

- **Unit Serial Number**
- **Product Name**

*The unit serial number and product name can be found on the serial number decal. See Chapter 7 for exact location of serial number decal.*

- **Part Description**
- **Part Number**

*Part descriptions and part numbers are located in Chapter 7 of this manual.*

- **Shipping Address**
- **Contact Name**

*In addition to your shipping address and contact name, your account number is helpful but not required.*

### **Return Material Authorization (RMA)**

The Return Material Authorization (RMA) system outlines the procedures to follow when returning material for placement, repair, or credit. The system assures that returned materials are properly handled and analyzed. Follow the following procedures carefully.

Contact your authorized Cybex dealer on all warranty-related matters. Your local Cybex dealer will request a RMA from Cybex, if applicable. Under no circumstances will defective parts or equipment be accepted by Cybex without proper RMA and an Automated Return Service (ARS) label.

1. Call the Customer Service Hotline listed above for the return of any time that is defective.
2. Provide the technician with a detailed description of the problem you are having or the defect in the item you wish to return.
3. Provide the model and serial number of your Eagle equipment
4. At Cybex's discretion, the technician may request that you return the problem part(s) to Cybex for evaluation and repair or replacement. The technician will assign you a RMA number and will send you an ARS label. The ARS label and the RMA numbers must be clearly displayed on the outside of the package that contains the item(s) to be returned. Include the description of the problem, the serial number of the Eagle equipment and the name and address of the owner in the package along with the part(s).
5. Forward the package through UPS to Cybex.  
Attn: Customer Service Department  
Cybex International, inc.,  
10 Trotter Drive  
Medway, MA 02053

**NOTE:** *Merchandise returned without an RMA number on the outside of the package or shipments sent C.O.D. will not be accepted by the Cybex receiving department.*



***Damaged Parts***

Materials damaged in shipment should not be returned for credit. Shipping damages are the responsibility of the carrier (UPS, Federal Express, trucking companies, etc.)

**Apparent Damage** - Upon receipt of your shipment, check all items carefully. Any damage seen with a visual check must be noted on the freight bill and signed by the carriers agent. Failure to do so will result in the carriers refusal to honor your damage claim. The carrier will provide you with the required forms for filing such claims.

**Concealed Damage** - Damage not seen with a visual check upon receipt of a shipment but notices later must be reported to the carrier as soon as possible. Upon discovery of the damage, a written or phone request to the carrier asking them to perform an inspection of the materials must be made within ten days of the delivery date. Keep all shipping containers and packing materials as they will be needed in the inspection process. The carrier will provide you with an inspection report and the necessary forms for filing a concealed damage claim. Concealed damage claim is the carriers responsibility.

*This page intentionally left blank*

## LIMITED WARRANTY FOR ALL CYBEX COMMERCIAL STRENGTH PRODUCTS

**NOTE: Save this document for your records.** This warranty includes all Cybex commercial Strength products, including: CYBEX "EAGLE", "FREE WEIGHT", "FUNCTIONAL TRAINER", "MODULAR", "MULTI-GYM", "PLATE LOADED", "VR" and "VR2" Products.

**WHO IS COVERED:** The original buyer purchasing the product from Cybex or its designee. Buyer includes any person receiving the product in an unused condition as a gift from the original buyer. The terms "you" and "your" are used in this Limited Warranty to refer to the original buyer and any person receiving the product as a gift from the original buyer. The terms "we," "us" and "our" are used in this Limited Warranty to refer to Cybex International, Inc. **This warranty covers all products sold under the Cybex "Eagle", "Free Weight", "Functional Trainer", "Modular", "Multi-Gym", "Plate Loaded", "VR" and "VR2" names and used in the continental United States. Products sold or moved outside the borders of the continental United States of America are subject to the terms provided by the local distributor, and are not covered under this warranty.**

**WHAT IS COVERED:** Except as otherwise stated in this Limited Warranty, we will repair or correct any product or part defect which we determine is related to materials or workmanship and is not due to normal wear and tear occurring during the stated WARRANTY PERIOD.

**WHAT IS NOT COVERED:** Product requires normal maintenance including, but not limited to, regular inspection and wear component replacement. We do not warrant damage caused by the lack of normal maintenance repairs such as those detailed within the Owner's Manual. We do not warrant any causes beyond our control. Corrosion, oxidation or deterioration caused by product location, exposure or environment, or conditions caused by unsuitable finishes, cleaners, or lubricants are not covered. Damage or breakage caused by unauthorized service, installation, alteration, modification, assembly or disassembly, negligence, or conditions of use which are unintended for the product are not warranted. This warranty does not cover cosmetic or surface corrosion resulting from chips or scratches in the paint. Extra expenses including, but not limited to, loss of machine use and inconvenience are not covered. Due to varying conditions under which the product is used, we offer no warranties, express or implied, as to the length of service. We do not warrant any products that have not been paid for, or in the event that we have offered a payment plan, products owned by buyers who are in arrears on a payment plan. If you are a non-consumer buyer, we only warrant products purchased directly from us or from one of our authorized dealers in that dealer's authorized territory. **THIS WARRANTY DOES NOT COVER UNINTENDED USE. See "INTENDED USE" below.**

**INTENDED USE:** This warranty covers only defects that arise in the ordinary, intended use of the product. Products sold under the Cybex "Eagle", "Free Weight", "Functional Trainer", "Modular", "Multi-Gym", "Plate Loaded", "VR" and "VR2" names are intended for commercial use, including use in health clubs and similar facilities.

**WARRANTY PERIOD:** The warranty period begins on the date the product was delivered to you. The warranty period for the structural frame expires after ten (10) years. The warranty period for rotary bearings, guide rods, pulleys, weight stacks, bushings, linear bearings, bars, handles, and all other parts not listed herein expires after two (2) years. The warranty period for cables and belts expires after one (1) year. The warranty period for upholstery and handgrips expires after one hundred twenty (120) days.

**WHO WILL PAY LABOR AND TRANSPORTATION COSTS:** If we determine, during the first

Refer to Next Page for Continuation of Limited Warranty

## **Cybox FT 360 Functional Trainer Owner's Manual**

year of the warranty period, that the product or any covered part must be shipped to the manufacturing facility for repair or service, all warranty repairs, including transportation costs and labor, will be made at NO CHARGE to you; thereafter, you will be responsible for labor and transportation costs for repair or service.

**WHAT YOU MUST DO TO OBTAIN WARRANTY COVERAGE:** Retain proof of purchase. All warranty repairs and corrections require proof of purchase. To obtain coverage, please contact Cybox Customer Service within seven (7) days after discovery of the defect and follow the directions provided to you by your Cybox Service Representative.

**WHAT WE WILL DO TO CORRECT COVERED REPAIRS:** Authorized repairs or corrections will be performed using new or remanufactured parts shipped to you, or at our discretion, replacement of the product. Any replacement parts provided to you are warranted for the remaining portion of the original WARRANTY PERIOD.

**MODIFICATIONS TO WARRANTY ARE NOT AUTHORIZED:** No one is authorized to modify, change, transfer or extend in any way the terms of this Limited Warranty.

### **THINGS TO KNOW ABOUT OBTAINING PRODUCT ACCESSORIES, PARTS AND REPAIR**

**SERVICE:** To secure repair service under this warranty, please contact Cybox Customer Service at (508) 533-4300, Monday - Friday from 8:00 - 6:00 p.m. Eastern time. To expedite service, please have your product serial number available when calling. Your customer service technician will assist you with any shipping or repair requirements deemed necessary to obtain repair or correction. A Return Authorization Number (RA#) is required when returning a product or part if the item is to be covered under warranty. We are not responsible for products or parts shipped to our facility without a RA#. All returns shall be accompanied by a proof of purchase to ensure warranty coverage. We may require the product or part be returned for inspection prior to making a warranty coverage decision.

You may also contact us by writing to: Cybox International, Inc., Attn: Customer Service Department, 10 Trotter Drive, Medway, MA, 02053.

**DISCLAIMER OF WARRANTIES AND LIMITATION OF REMEDIES:** It is impossible to eliminate all risks inherently associated with use of this product. Personal injury or other unintended consequences may result because of factors beyond our control. WE MAKE NO OTHER WARRANTIES OF ANY KIND, EXPRESS OR IMPLIED, OTHER THAN THOSE EXPRESSLY SET FORTH WITHIN THIS DOCUMENT. ALL WARRANTIES OTHER THAN THE WARRANTIES EXPRESSLY PROVIDED HEREIN ARE SPECIFICALLY EXCLUDED. IN THE CASE OF NON-CONSUMER BUYERS, ALL IMPLIED WARRANTIES OF MERCHANTABILITY AND FITNESS FOR A PARTICULAR PURPOSE ARE HEREBY DISCLAIMED.

IN THE CASE OF A CONSUMER BUYER, THE DURATION OF ALL IMPLIED WARRANTIES OF MERCHANTABILITY OR FITNESS FOR A PARTICULAR PURPOSE IS LIMITED TO THE DURATION OF THE EXPRESS WARRANTIES PROVIDED WITHIN THIS DOCUMENT.

WE WILL NOT BE LIABLE FOR ANY DIRECT OR INDIRECT, CONSEQUENTIAL OR INCIDENTAL DAMAGES, LOSSES OR EXPENSES, INCLUDING BUT NOT LIMITED TO COMMERCIAL LOSSES, BUSINESS INTERRUPTION, OR DAMAGE TO PROPERTY OTHER THAN THE PRODUCT OR PRODUCTS TO WHICH THIS LIMITED WARRANTY APPLIES.

**EFFECT OF STATE LAWS:** Some States do not allow limitations on how long an implied warranty lasts, so the above limitation may not apply to you. Some States do not allow the exclusion or limitation of incidental or consequential damages, so the above limitation or exclusion may not apply to you. This warranty gives you specific legal rights, and you may also have other rights which vary from State to State.

**ALTERNATIVE DISPUTE RESOLUTION FOR NON-CONSUMER BUYERS:** WE RESERVE THE RIGHT TO MANDATE ALTERNATIVE DISPUTE RESOLUTION TO SETTLE ANY OR ALL CLAIMS RESULTING FROM THIS SALES TRANSACTION. ALTERNATIVE DISPUTE RESOLUTION PROCEEDINGS WILL BE CONDUCTED IN THE STATE OF MASSACHUSETTS ACCORDING TO THE COMMERCIAL RULES OF THE AMERICAN ARBITRATION ASSOCIATION.

# 6 - Assembly

FT 360 Diagram

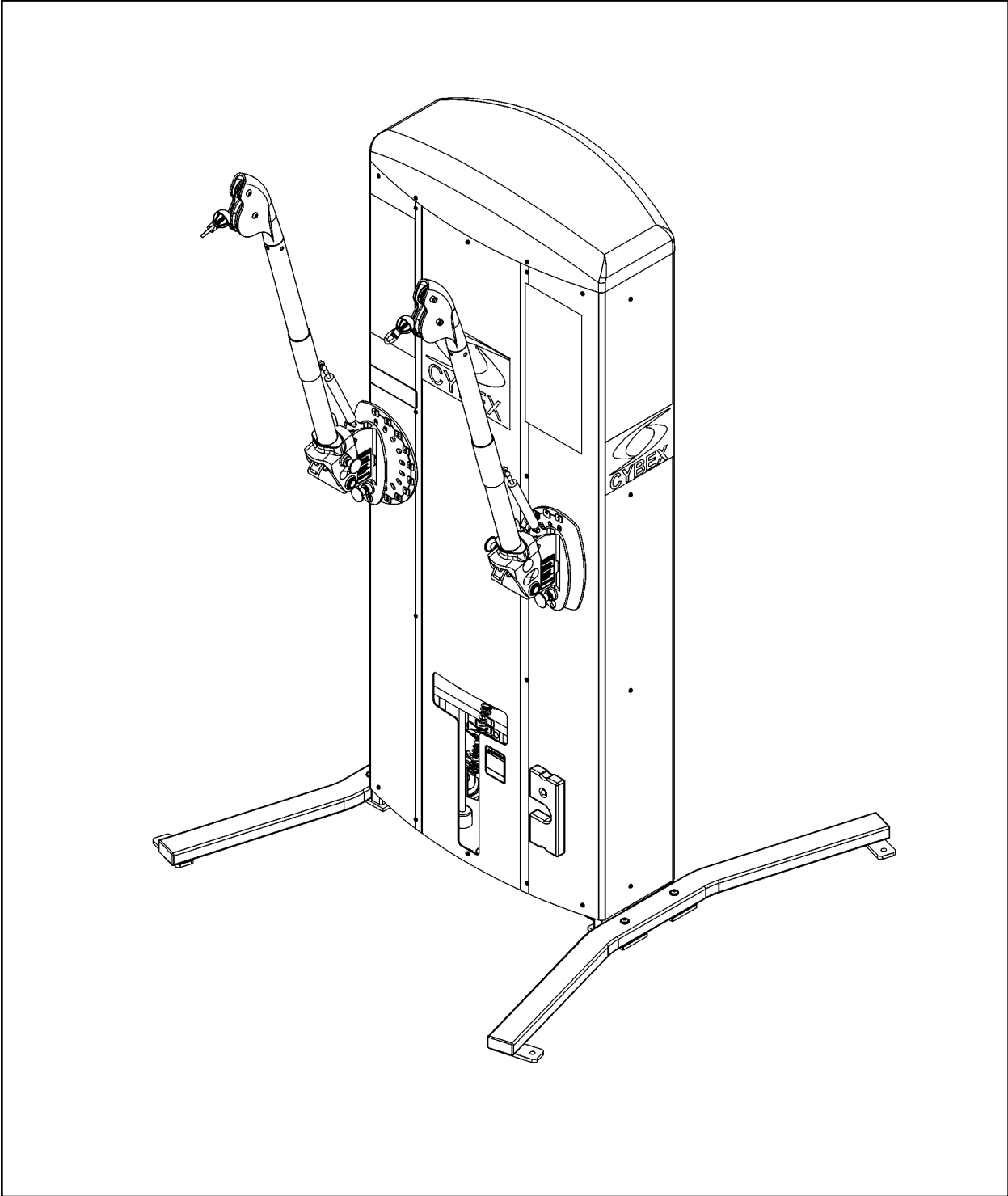

**! WARNING:** Use extreme caution when assembling the FT 360, especially when working on the inside of the assembly. Failure to do so could result in injury.

**Tools Required**

- 7/32" Allen wrench
- 5/16" Socket/wrench
- 9/16" Socket/wrench
- External snap ring pliers
- Rubber mallet
- Step ladder
- Automotive engine oil
- Utility knife

**Unpacking**

**NOTE:** Two people are required to assemble the FT 360.

**1. Read and understand all instructions thoroughly before assembling the FT 360.**

**NOTE:** Each step number in the assembly instructions tells you what you will be doing. The lettered steps following each step number describes the procedure required. Do not continue with step 2 until you have carefully read all of the assembly instructions.

**2. Unpacking** (see steps 2A - 2D), Figures 1 and 2. **NOTE:** Steps 2B and 2C have already been completed.

- A.** Carefully place FT 360 near area of installation. You will need a minimum amount of three feet around the FT 360 (when in use).
- B.** Remove screws securing back door. Swing door open.
- C.** Remove carton and stabilizers from inside of FT 360.
- D.** Verify contents of the carton. See Figures 1 and 2.

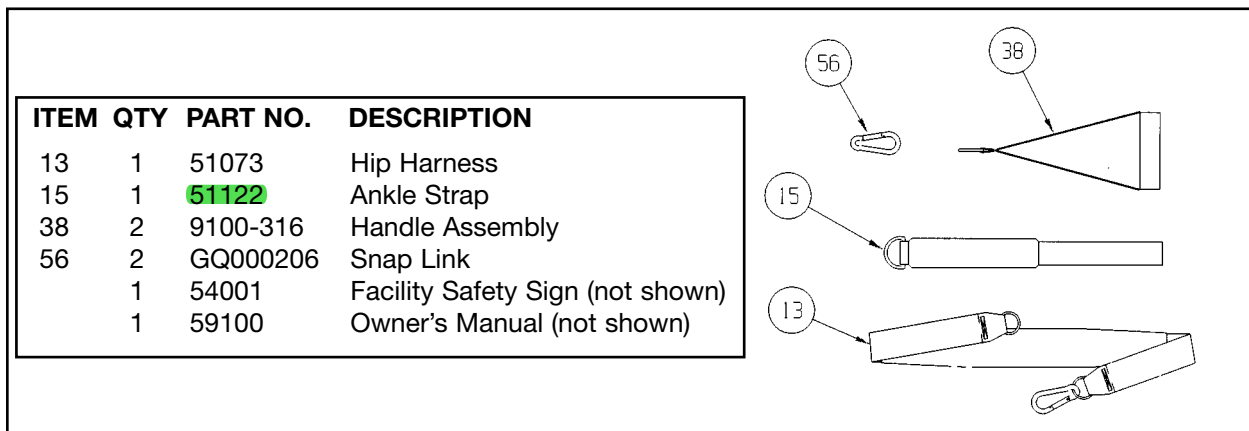

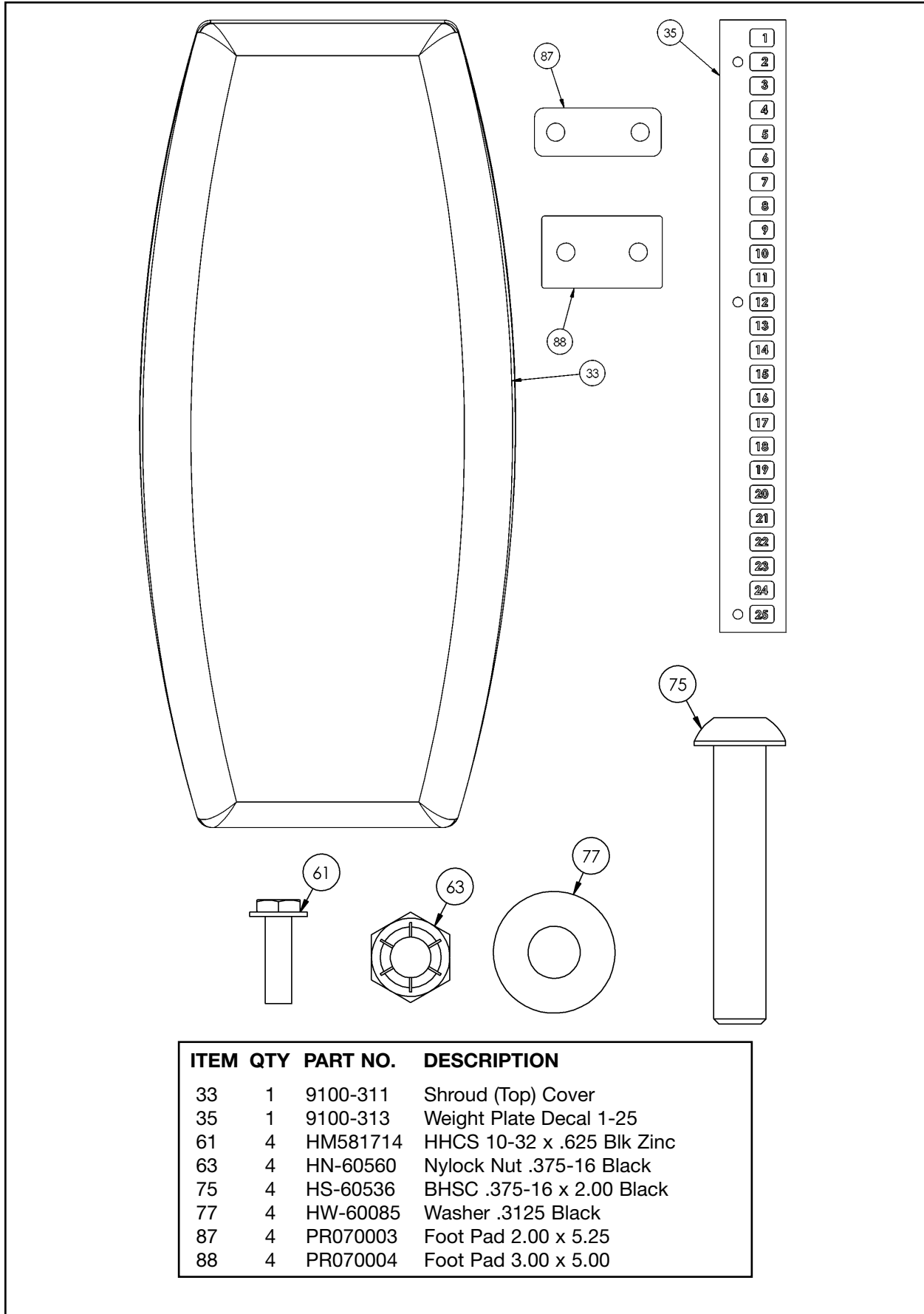

Figure 2

## Installing Foot Pads

**! WARNING:** Use extreme caution when installing foot pads. Failure to do so could result in injury.

**NOTE:** A minimum of two people will be required to remove the FT 360 from the pallet.

**1. Remove FT 360 from pallet** (see steps 1A - 1C and Figure 1).

- A.** Remove the four bolts securing the FT 360 to the pallet. See Figure 1.
- B.** With one person on each side, carefully lift FT 360 and remove FT 360 from pallet.
- C.** Place FT 360 where it will be used.

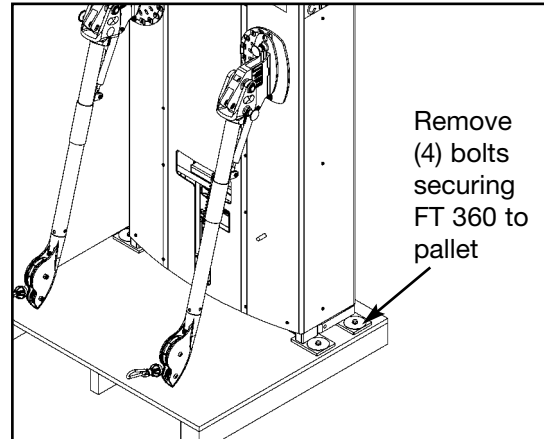

Figure 1

**2. Installing foot pads onto stabilizers** (see steps 2A - 2D and Figure 2).

- A.** Locate four foot pads 2.00 x 5.25 (#87) and two stabilizers (#89D).
- B.** Lay one of the stabilizers (#89D) so that the bottom side is facing up. See Figure 2.
- C.** Remove the backing from two of the foot pads and install foot pads 2.00 x 5.25 (#87) as shown in Figure 2.
- D.** Repeat steps A - C for other stabilizer.

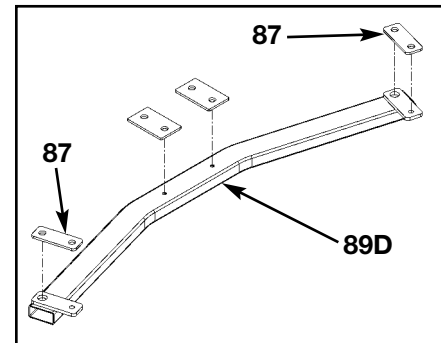

Figure 2

**3. Installing foot pads onto frame** (see steps 3A - 3E and Figure 3).

- A.** Locate four foot pads 3.00 x 5.00 (#88).
- B.** Carefully tip FT 360 forward (do not exceed 30 degrees) or just enough to install the foot pads. See Figure 3 on next page.
- C.** While one person is holding the FT 360 in a tipped position, remove the backing from two of the foot pads and install foot pads 3.00 x 5.00 (#88) onto frame as shown in Figure 2 and then carefully lower FT 360.
- D.** Carefully tip FT 360 backwards (do not exceed 30 degrees) or just so that there is enough room to install two of the foot pads.
- E.** Repeat step C.



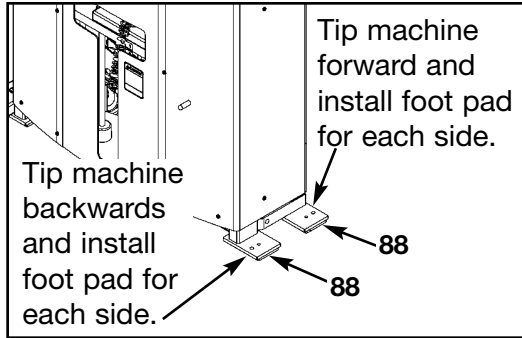

Figure 3

**4. Installing stabilizers** (see steps 4A - 4D and Figure 4).

- A. Locate four BHSCS .375-16 x 2.00 (black, #75), four black washers .3125 (#77), and two stabilizers (#89D).
- B. Align one of the stabilizers with the holes in the frame. See Figure 4.
- C. Secure the stabilizer using two BHSCS .375-16 x 2.00 (black, #75) and two black washers .3125 (#77) as shown in Figure 4.
- D. Repeat steps 4B - 4C for installing the other stabilizer.

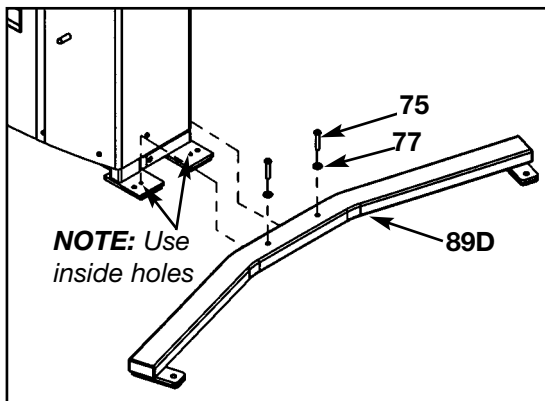

Figure 4

**Installing Snap Links**

**1. Installing snap links** (refer to step 1A, 1B and Figure 1).

- A. Rotate arms to #4 position.
- B. Locate the two snap links (#56).
- C. Attach each snap link (#56) to cable on each cable arm. See Figure 1.

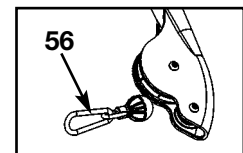

Figure 1

## Installing Weight Stacks

**! WARNING:** Use extreme caution when installing the weight stack. Failure to do so could result in injury.

**NOTE:** Two people will be required to perform this procedure.

1. **Disconnect lower end of each spring** (refer to steps 1A - 1F and Figure 1).
  - A. Move arm from the #4 position to the #10 position.
  - B. Firmly grasp lower end of spring.
  - C. Stretch spring downward with one hand.
  - D. With your other hand, remove cable end connector from spring (hook).
  - E. Carefully release spring and set cable down.
  - F. Repeat steps 1A - 1E to disconnect lower end of other spring.

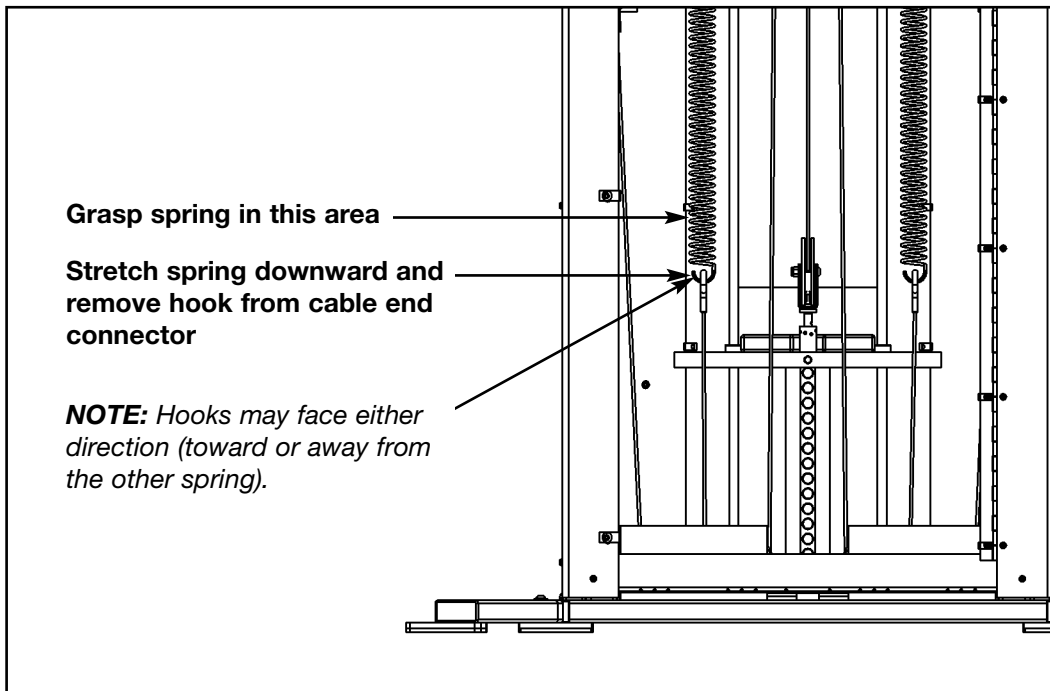

Figure 1

**2. Disconnect upper end of each spring** (refer to steps 2A - 2E, Figures 2 and 3).

**A.** Firmly grasp upper end of spring. See Figure 2.

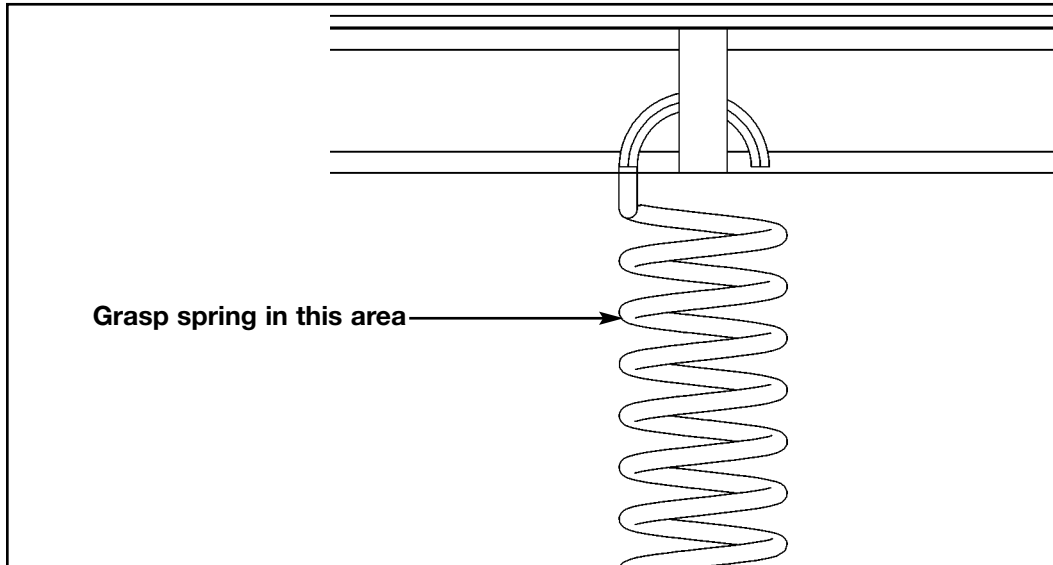

Figure 2

**B.** Flex (bend) upper part of spring approximately 90 degrees. See Figure 3.

**C.** Slide hook outward and remove from connector. See Figure 3.

**D.** Set spring aside.

**E.** Repeat steps 2A - 2D to disconnect upper end of other spring.

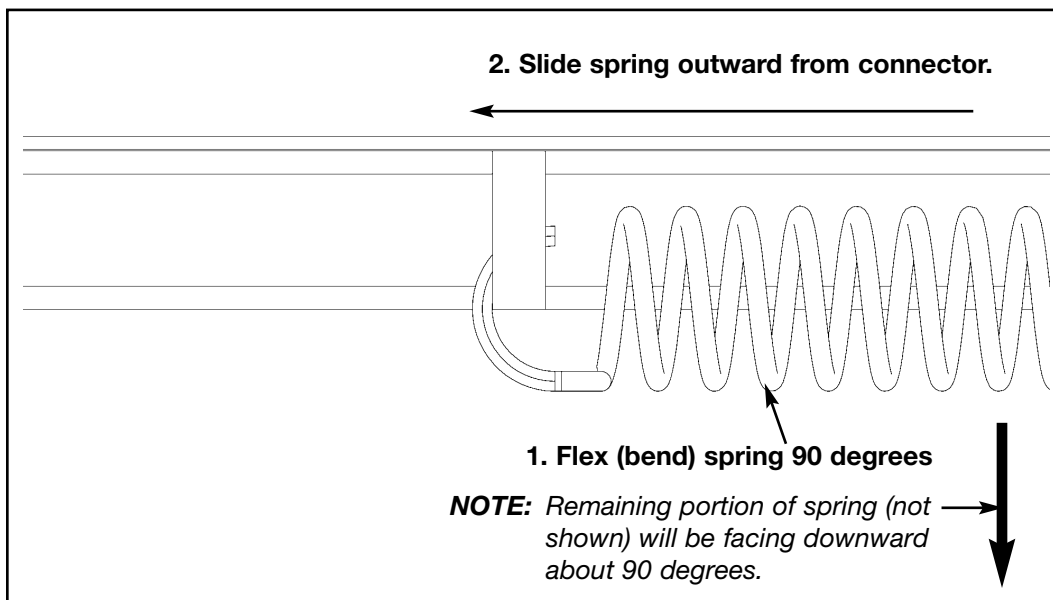

Figure 3

3. Removing pulley (refer to steps 3A - 3C and Figure 4).

A. Have an assistant hold the top pulley shown in Figure 4.

**! CAUTION:** *If an assistant does not hold pulley while performing step 3B then pulley will fall and may drop on your head.*

B. Remove pulley from top weight connector. **NOTE:** *Lift top weight slightly when removing pulley.*

C. Hang portion of cable over the door so the cable will be out of the way when installing the weight stack.

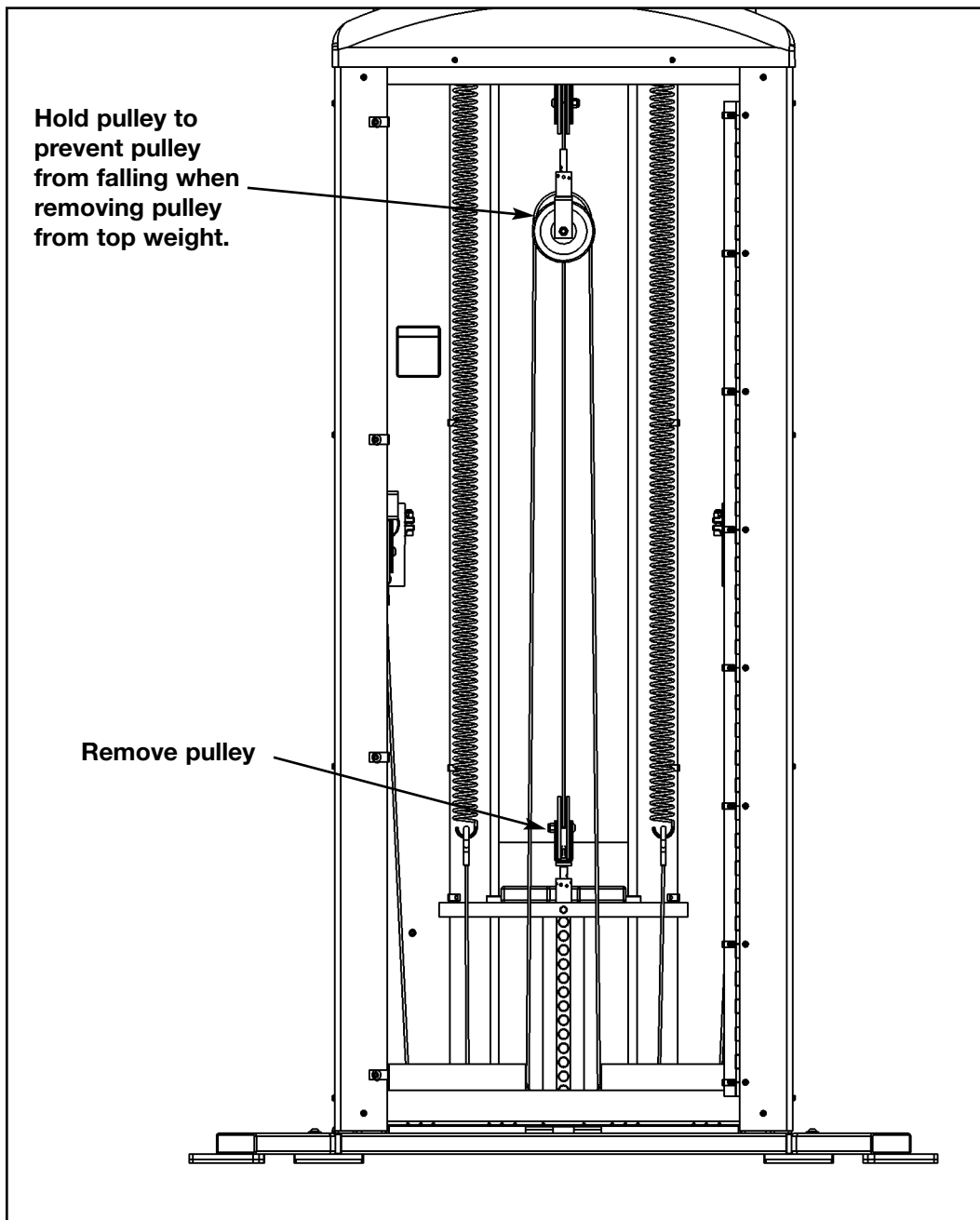

**! WARNING:** Use extreme caution when installing the weight stack. Failure to do so could result in injury.

**NOTE:** Two people will be required to perform this procedure.

**4. Install Weight Stack** (refer to steps 4A - 4O and Figures 5 - 7).

- A.** Using an external snap ring pliers, slide the lower snap ring (and wave washer) down about two inches from the top part of the guide rod (this will provide access to the upper ring). Repeat this step for the other guide rod. See Figure 5.

**NOTE:** A step ladder will be required when removing snap rings.

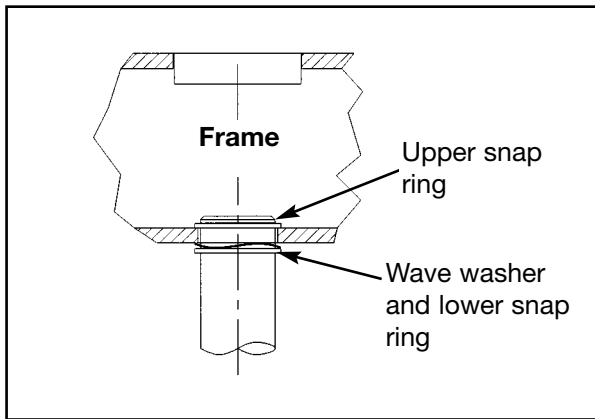

Figure 5

- B.** Raise one of the guide rods high enough to expose the upper snap ring. Using an external snap ring pliers, remove upper snap ring and then lower guide rod.
- C.** Remove lower snap ring and wave washer.
- D.** Slightly lift and lean guide rods outward.
- E.** Using a utility knife, carefully remove the packaging material securing the half weight to the top weight.
- F.** Remove the half weight and hang it on the half weight hanger (located on front).
- G.** Carefully remove top weight.
- H.** Wipe guide rods clean over entire length. Lubricate with light coating of medium weight automotive engine oil.
- I.** With an assistant, carefully install each weight plate one at a time.

**! WARNING:** Use extreme caution as weight stack is unstable until guide rods are secure. Failure to do so could result in injury.

- J. Carefully slide top weight onto guide rods.
- K. On one of the guide rods, place lower snap ring and wave washer at least two inches below top end of guide rod. Carefully lean guide rods back inside of column into guide rod holes.

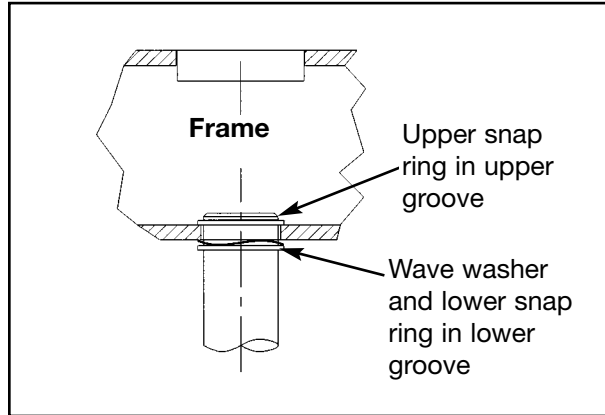

Figure 6

- L. Raise guide rod up through mounting hole and install the upper snap ring into the upper groove of the guide rod. See Figure 6.
- M. Lower guide rod and secure wave washer and lower snap ring. See Figure 6.

**NOTE:** Snap rings must be installed into the groove for proper installation.

- N. Repeat steps K - M for securing the other guide rod.
- O. Move pulley and cable back inside the column and reinstall pulley/cable back onto top plate. See Figure 7.

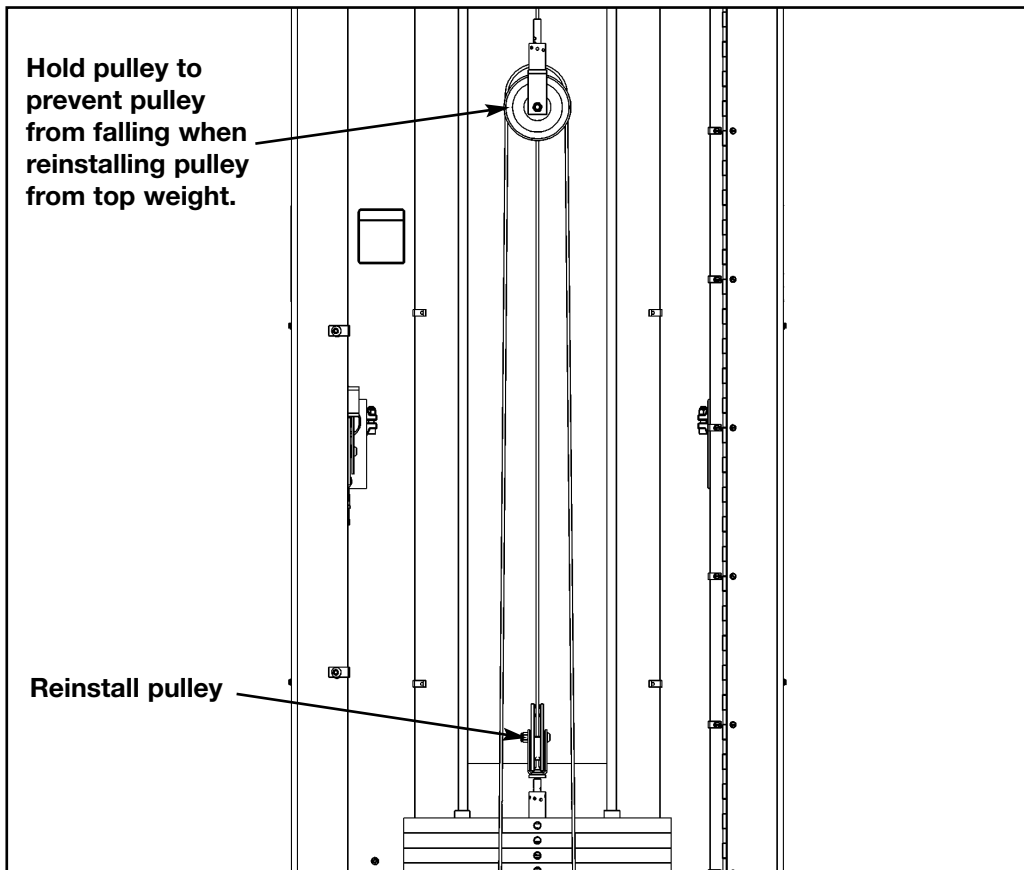

Figure 7

**2. Connect upper end of each spring** (refer to steps 2A - 2E, Figures 8 and 9).

- A.** Firmly grasp upper end of spring. See Figure 8.
- B.** Flex spring approximately 90 degrees. See Figure 9.
- C.** Slide hook outward and remove from connector. See Figure 9.
- D.** Set spring aside.
- E.** Repeat steps 2A - 2D to disconnect upper end of other spring.

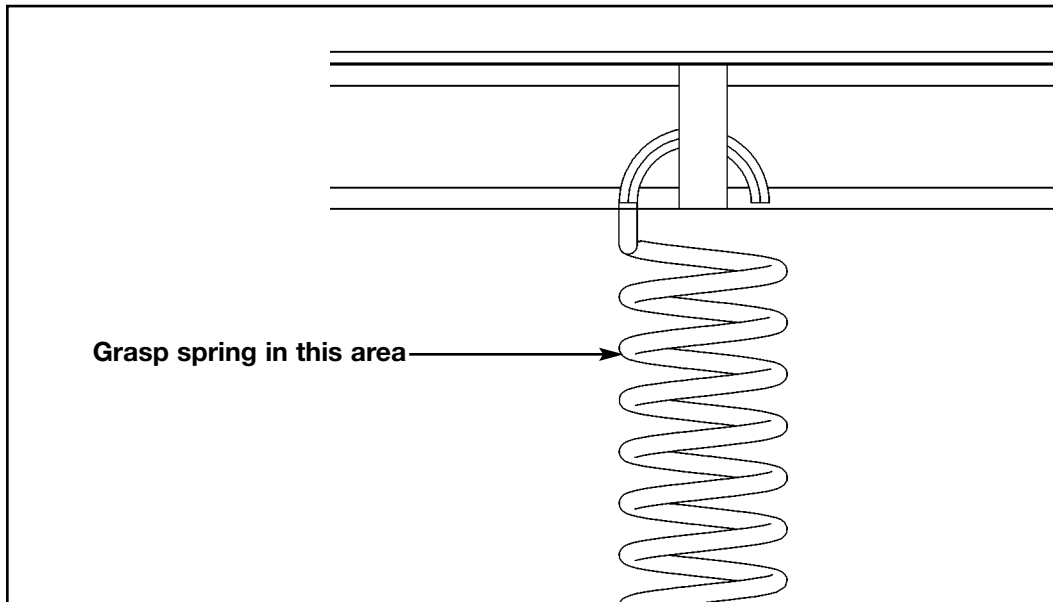

Figure 8

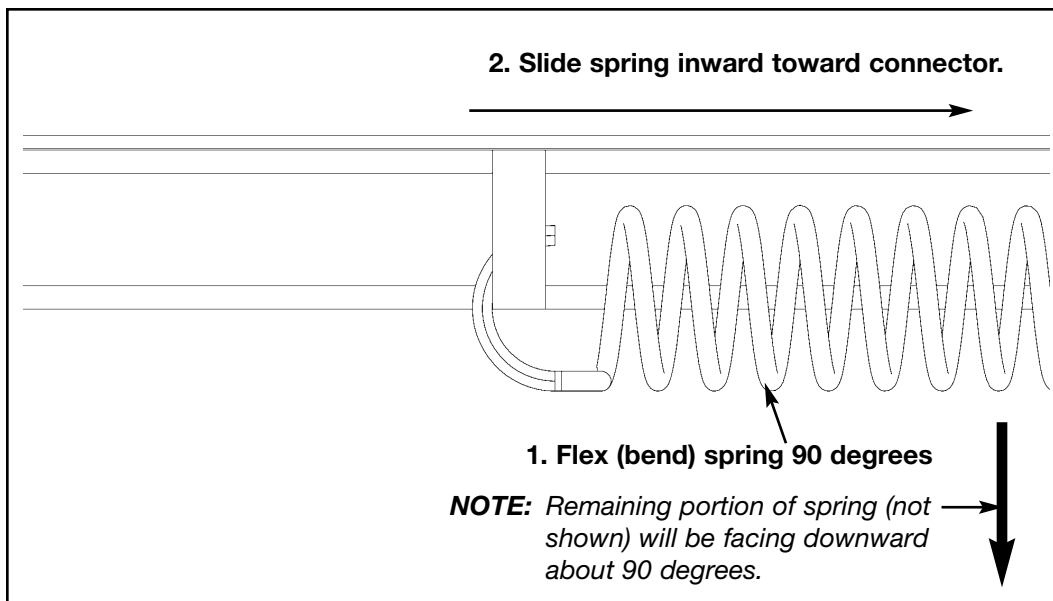

Figure 9

**! WARNING:** Use extreme caution when installing the springs. Failure to do so could result in injury.

5. Reconnect lower end of each spring (refer to steps 5A - 5D and Figure 10).

- A. Firmly grasp lower end of spring.
- B. Stretch spring downward with one hand.
- C. With your other hand, connect cable end connector to spring (hook).
- D. Repeat steps 1A - 1C to connect lower end of other spring.

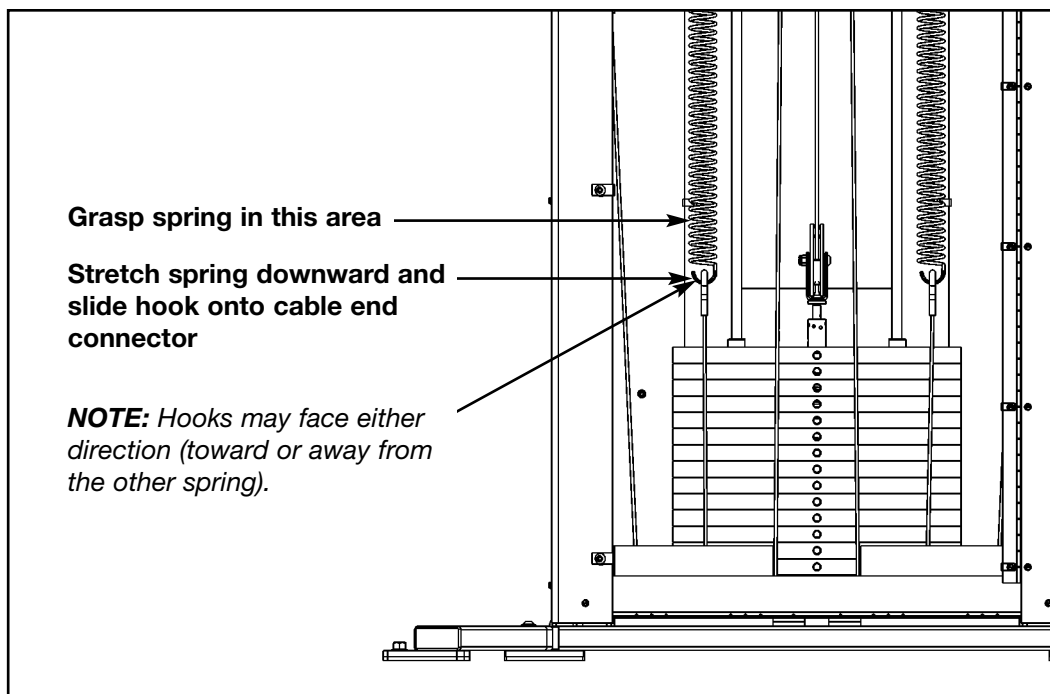

Figure 10

6. Install weight plate decals (see steps 5A - 5E and Figure 11).

- A. Locate the weight stack number decal. **NOTE:** Not all 25 number decals will be used.
- B. Carefully peel the backing off the decal. Align holes in decal with holes with appropriate holes in weight stack. **NOTE:** Do not allow adhesive to touch weight stack at this time.
- C. Insert a guide rod through each hole of the template. **NOTE:** A guide rod can be anything that fits through the weight stack hole, such as a weight stack selector pin.
- D. Carefully align and rub decal onto weight plates.
- E. Carefully remove front side, leaving numbers adhering to weight plates.



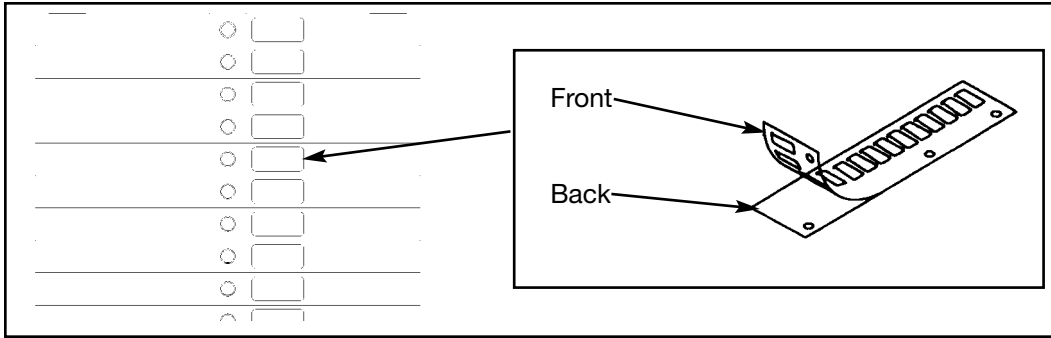

Figure 11

### Installing Shroud

1. **Locate shroud (top) cover** (see steps 1A - 1B and Figure 1).
  - A. Locate shroud (top) cover (#33) and four HHCS 10-32 x .625 (#61).
  - B. Attach shroud (#33) using the four HHCS (#61) located in step 1A. See Figure 1.

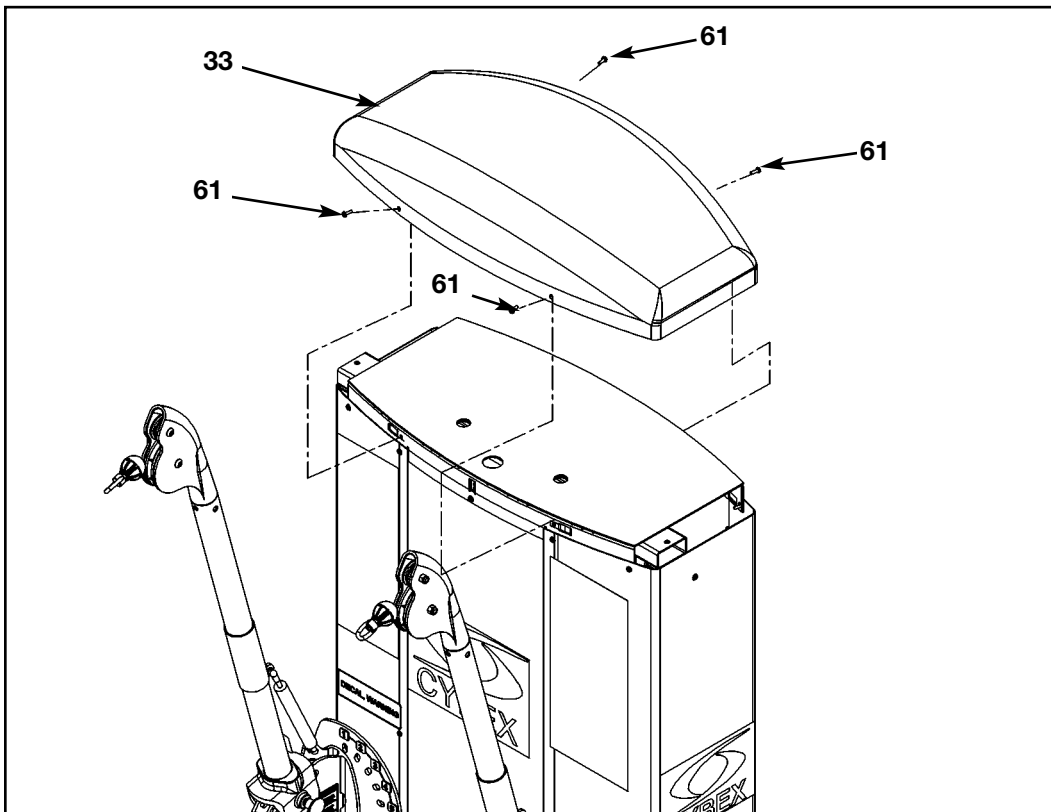

Figure 1

**Final Assembly**

**1. Visual Inspection** (see step 1A).

- A.** Visually inspect the entire FT 360. Be sure cables are properly installed, hardware is secure and the weight stack is properly assembled.
- B.** Verify Caution Decal, part number 9100-348 is present and not damaged. See Figure 1 to identify what the decal looks like and see Figure 2 for location.



Figure 1

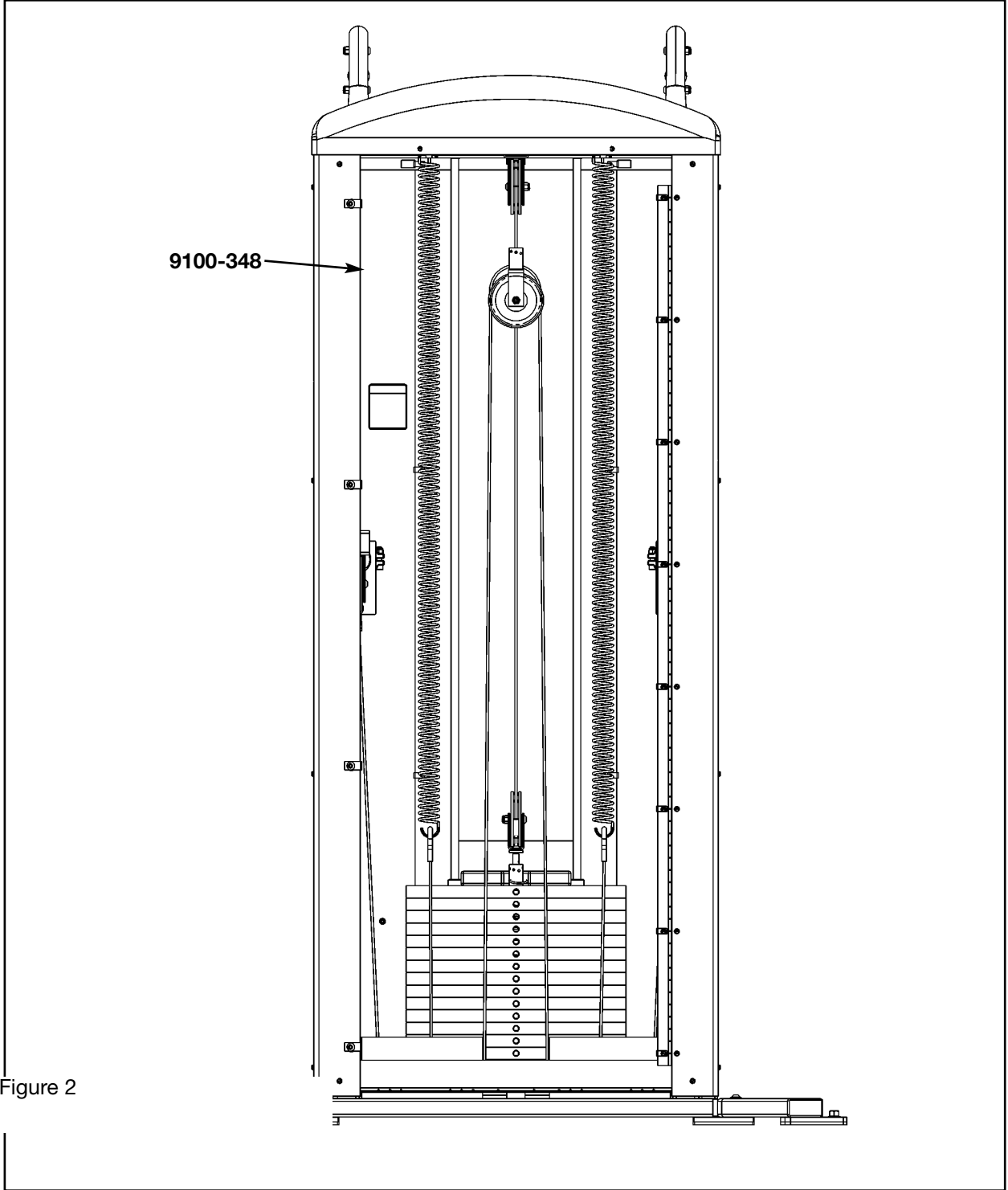

Figure 2

- C. Verify the Warning and Caution Decal, part number 9100-348 is present and not damaged. See Figures 3 and 4 to identify what the decals look like and their proper location.

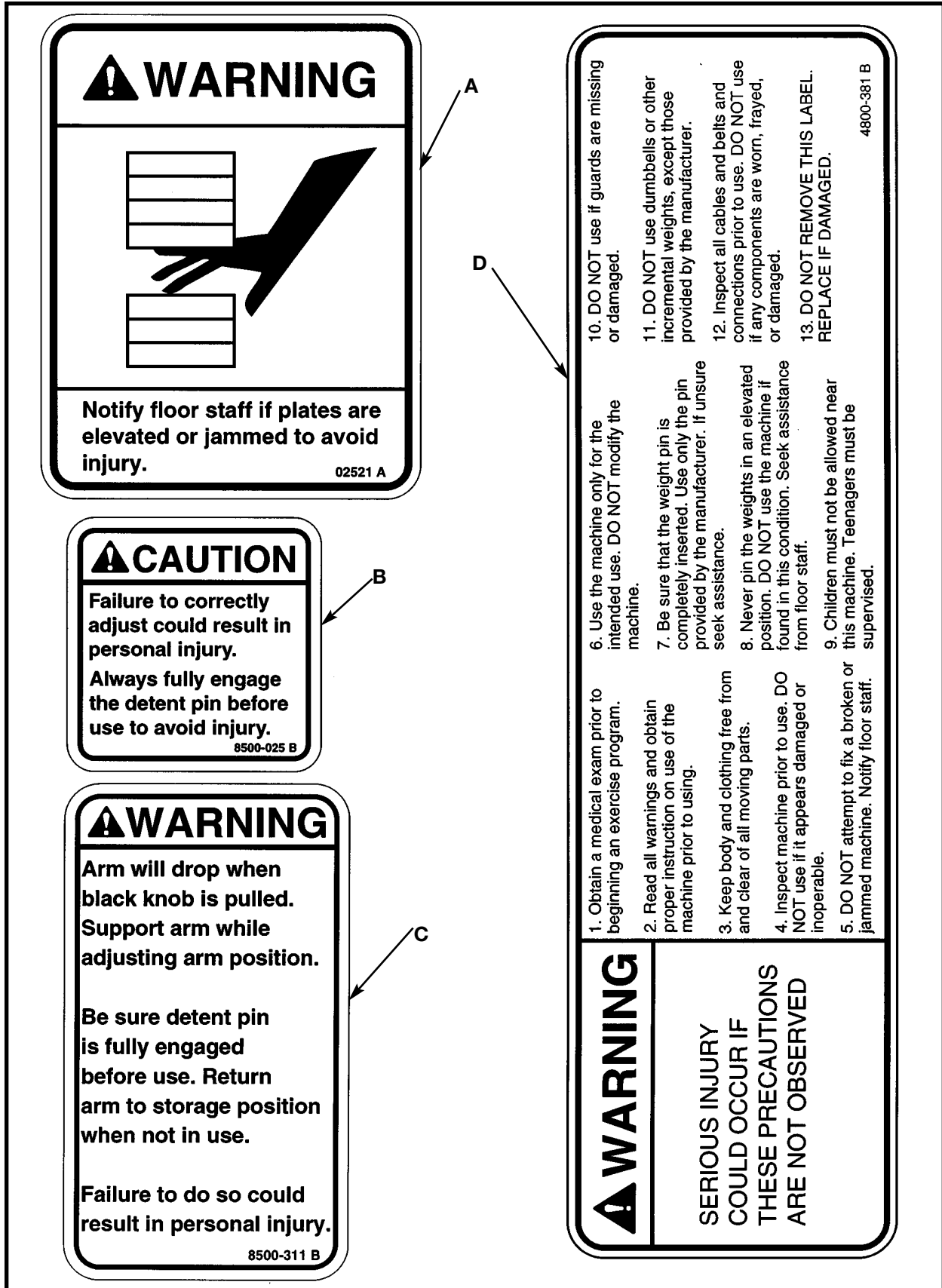
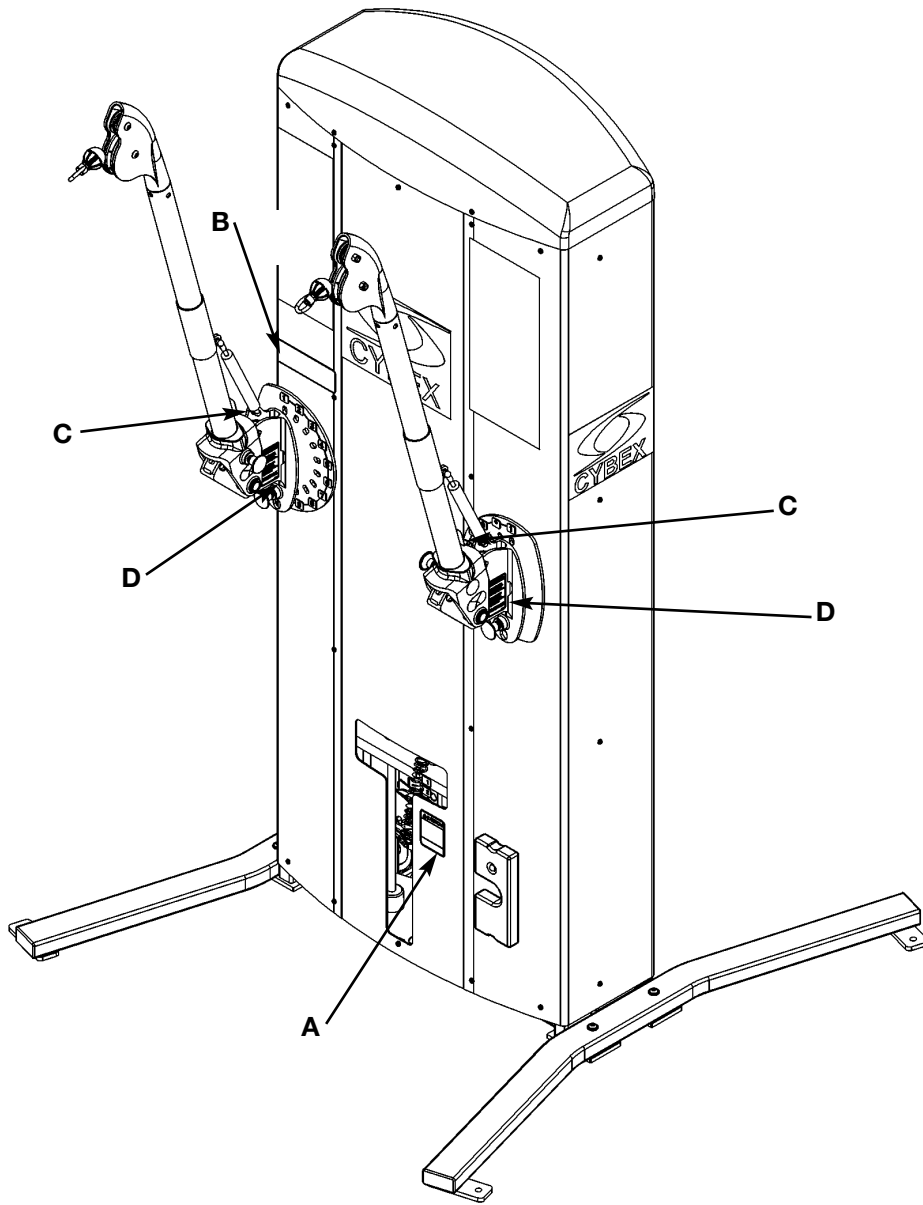

Figure 3



DESCRIPTION	PART NO.
A. Warning Decal .....	02521
B. Warning Decal .....	4800-381
C. Caution Decal .....	8500-025
D. Warning Decal.....	8500-311

Figure 4

**2. Close back cover** (see step 2A).

- A. Close back cover and secure using the same screws removed when opening the back cover (at the beginning of assembly).

**3. Functional inspection** (see step 3A).

- A. Check for proper operation.
- B. Leave handles, ankle strap and hip harness on or near machine.

## 7 - Maintenance

All preventive maintenance activities must be performed on a regular basis. Performing routine preventive maintenance actions can aid in providing safe, trouble-free operation of your Cybox FT 360 Functional Trainer.

**NOTE:** *Cybox is not responsible for performing regular inspection and maintenance actions for your machines. Instruct all personnel in equipment inspection and maintenance actions and also in accident reporting/recording. Cybox phone representatives are available to answer any questions or concerns that you may have.*



**NOTE:** *All inspections and repairs must be performed by trained service personnel only.*

**Cybox will void warranty if non-Cybox replacement parts are used.**

## **Daily Procedures**

### **Please Review Carefully**

When using strong cleaning agents such as rubbing alcohol or bleach, it is advisable to first test in an inconspicuous area. Other cleaning agents may contain harsh or unknown solvents and are subject to formula changes by the product manufacturer without notice. Should you desire to use other cleaning agents, carefully try them in an inconspicuous area to determine potential damage to the material. Never use harsh solvents or cleaners which are intended for industrial applications. To clean stained or soiled areas, a soft white cloth is recommended. Avoid use of paper towels.

Cleaning products may be harmful/irritating to your skin, eyes, etc. Use protective gloves and eye protection. Do not inhale or swallow any cleaning product. Protect surrounding area/clothing from exposure. Use in a well ventilated area. Follow all product manufacturer's warnings. Cybox and its vendors cannot be held responsible for damage or injuries resulting from the use or misuse of cleaning products.

1. **Frames** - Wipe down frame using a mild solution of warm water and car wash soap. Be sure to dry thoroughly. **AVOID** acid or chlorine based cleaners and also cleaners containing abrasives as these could scratch or damage the equipment.
2. **Chrome** - Clean chrome tubes, first using chrome polish and then using a car wax seal. Neutral cleaners with a pH between 5.5 and 8.5 are recommended. Be sure to dry thoroughly. **AVOID** acid or chlorine based cleaners and also cleaners containing abrasives as these could scratch or damage the equipment.
3. **Front Panel** - The following techniques for cleaning the FT 360 front pane are based on standard industry practice. To ensure acceptability of results, always test a sample of the material with the cleaner and technique to be used.

### **Guidelines for cleaning front panel:**

- Use clean soft cloths or sponges for application of cleaners and again for washing and rinsing.
- Follow up the application with warm water rinse.
- Don't use abrasives or high alkaline cleaners.
- Don't leave cleaners on for long periods, wash immediately.
- Don't apply cleaners in direct sunlight or at elevated temperatures.
- Don't use scrapers, squeegees or razors.
- Don't clean with gasoline.



**Compatible Cleaners and Detergents:**

- Formula 409
- Top Job
- Joy
- Palmolive
- Windex with Ammonia D

**To Minimize Fine or Hairline Scratches:**

Mild automotive polish applied and removed with a soft, clean cloth will help fill scratches.

**Suggested Polishes:**

- Johnson Paste Wax
- Mirror Glaze #10 Plastic Polish (by Mirror Bright Polish Co.)
- Novus Plastics Polish #1, #2 (by Novus Inc.)

**Weekly Procedures**

1. Inspect all nuts and bolts for looseness. Tighten as required.
2. Inspect all cables for wear or damage and proper tension. When inspecting cables, run your fingers on the cable, paying particular attention to bends in the cable and attachment points.

**! WARNING: Replace all worn cables immediately. The following conditions may indicate a worn cable:**

- A tear or crack in the cable sheath that exposes the cable. See Figure 1.

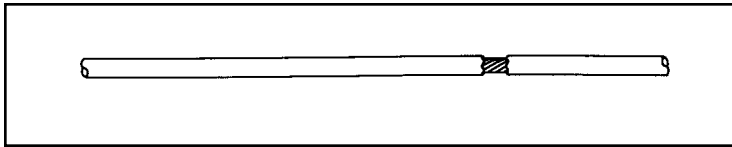

Figure 1

- A kink in the cable. See Figure 2.

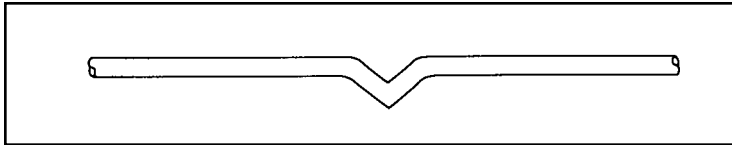

Figure 2

- A curled sheath. See Figure 3.

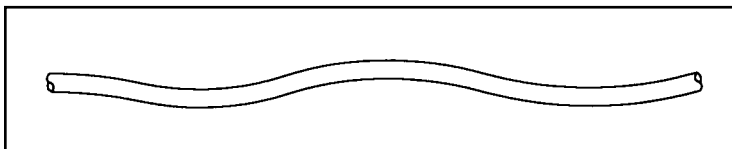

Figure 3

- "Necking", a stretched cable sheath. See Figure 4.

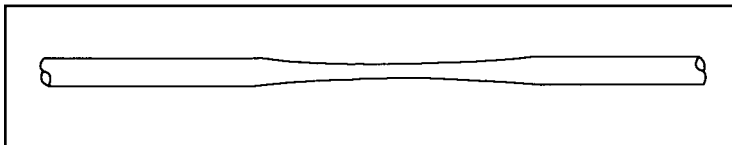

Figure 4

3. Inspect handles for wear, paying particular attention to connecting points.

***! CAUTION: Replace all worn handles immediately.***

4. Inspect snap links for proper latching (indicates wear). Replace all worn snap links immediately.
5. Inspect detent pins for excessive wear and free movement.
6. Inspect all labeling for readability. This includes instructional placards, warning and caution decals. Replace all worn labeling immediately.
7. Inspect all weight stacks for proper alignment and operation.

***NOTE: Correct all improper alignment and operation issues immediately.***

8. Wipe weight stack guide rods clean over entire length. Lubricate with a light coat of medium weight automotive engine oil.

### ***Yearly Procedures***

Replace all cables at least annually.

### ***“As Required” Procedures***

Inspect grips and replace as necessary.

## Weight Stack Cable Adjustment

### Tools Required:

- 3/16" Punch
- Hammer

1. Note roll pin location in cable fitting. See Figure 8.

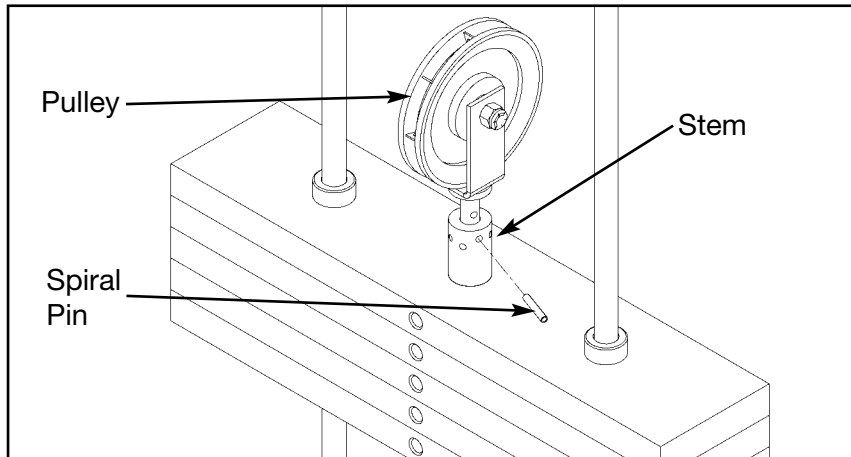

Figure 8

2. Using a 3/16" pin punch and hammer, drive spiral pin out of top plate connector and cable fitting.
3. Grip cable fitting firmly, pull down to tighten cable. Rotate fitting to align spiral pin hole with an opening in top plate connector.
4. Insert pin punch through top plate connector and spiral pin hole to hold cable in place.
5. Drive spiral pin through top plate connector and fitting from opposite side, pushing out pin punch. Assure spiral pin ends are flush.

### **Arm Cable Adjustment**

1. Insure top plate is in full contact with lower plates, and there is no space between any weight plate. Open the back door, and adjust threaded cable end, at center front inside of machine, until the ball stops at the end of the arms, are just in contact with the arm pulleys.
2. If the threaded adjustment does not have enough range, loosen the lock nut and adjust the threaded end to the initial position, (1/8" protruding beyond the lock nut). Tighten the cable at one or both of the other two adjustment location to absorb as much cable as possible then adjust the threaded cable end per step 1.
3. To loosen cable reverse the procedure in steps #1 and #2.
4. Check that the selector pin will enter each weight position after adjustment, and close the back door, and secure with four screws.

*This page intentionally left blank*

## 8 - Service

Please refer to the next several pages for parts lists, exploded-view diagrams and cable routing diagrams.



*NOTE: All inspections and repairs must be performed by trained service personnel only.*

**Cybex will void warranty if non-Cybex replacement parts are used.**

*This page intentionally left blank*



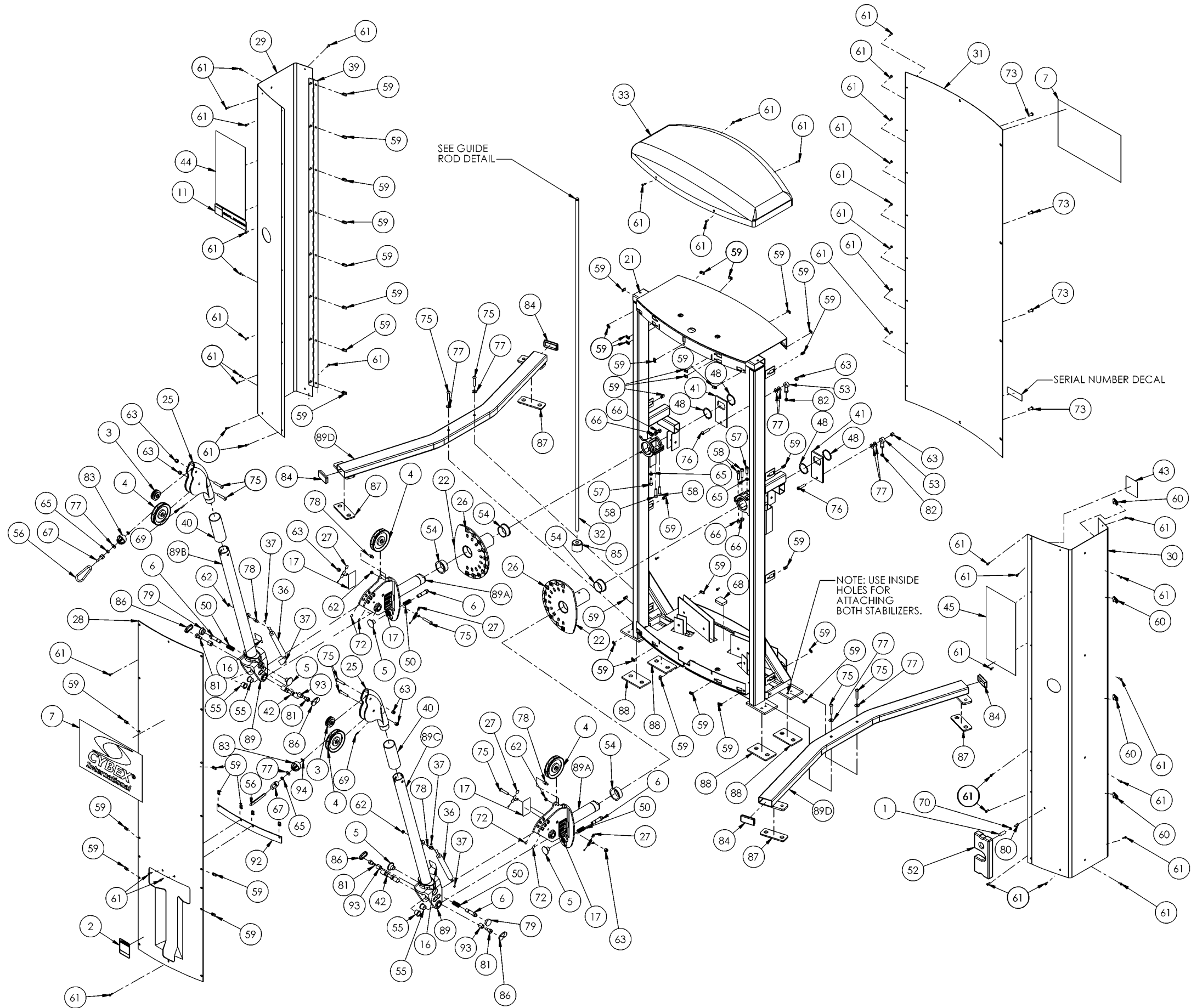

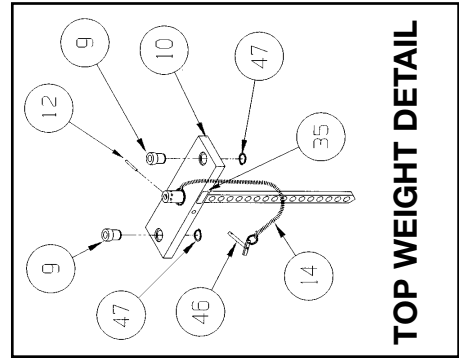
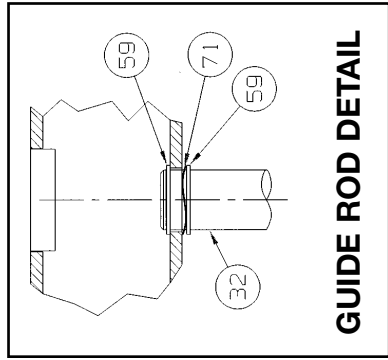
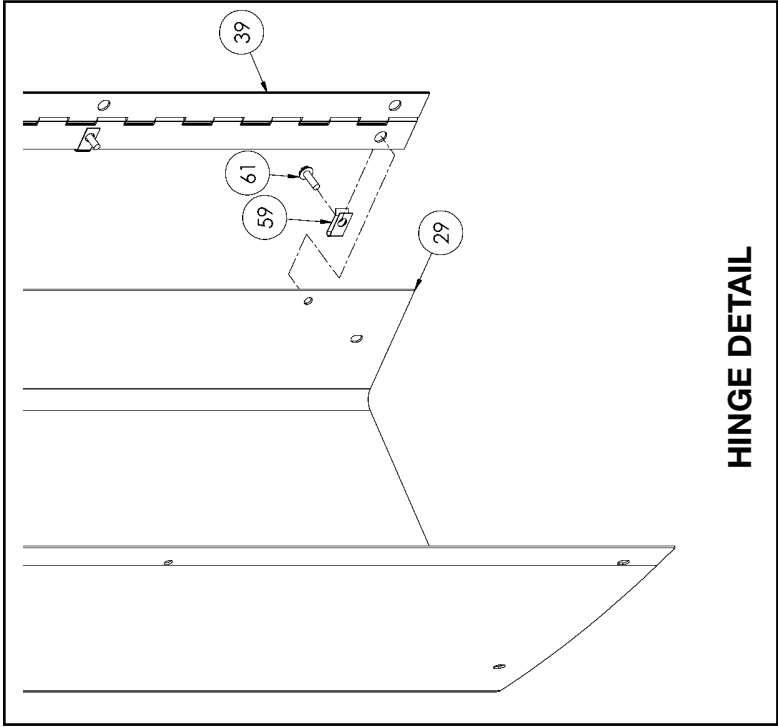
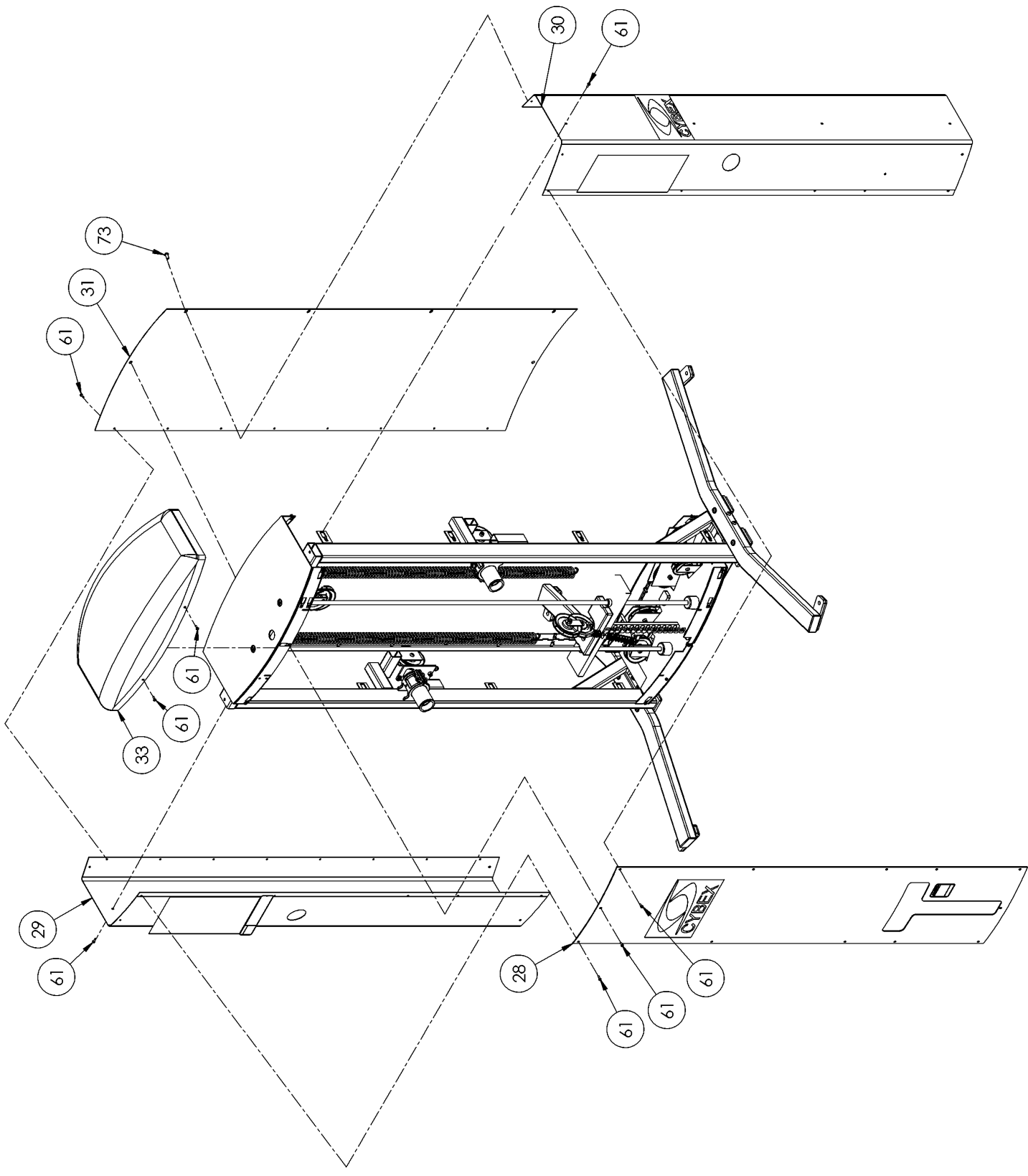

**9100 - FT 360 Station**

ITEM	QTY	PART NO.	DESCRIPTION
1	1	02106	Half Weight Peg
2	1	02521	Warning Decal
3	2	PW-60615	Pulley Cable 2.00 OD x 1.00 Hub
4	15	08014	Pulley Assembly 4.50 inch
5	4	11040-440	Cybex Knob
6	4	08229	Detent Pin
7	2	3900-438	Cybex Decal 8.75 x 13.00
8			Removed
9	2	4700-019	Flange Bearing .62 ID x .95 OD x 1.50 L
10	1	4800-255	Top Weight 4 x 18
11	1	4800-381	Warning Decal
12	2	HP286819	Spiral Pin .188 x 1.12
13	1	51073	Hip Harness
14	1	51119	Selector Pin Retainer
15	1	51122	Ankle Strap
16	2	8500-025	Caution Decal
17	4	8500-311	Max Weight Decal
18	1	9100-003	Cable Sub Assembly
19	2	9100-004	Cable Sub Assembly
20	1	9100-005	Cable Sub Assembly
21	1	9100-200	Main Frame
22	2	9100-204	Arm Adjustment
23	1	9100-205	Pulley Plate
24	1	9100-206	Pulley Traveler
25	2	9100-303	Molded Pulley Swivel
26	1	9100-304	Rotational Position Decal 1-10 (part number includes quantity of 2)
27	2	9100-305	Position ABC Decal (part number includes quantity of 2)
28	1	9100-306	Shroud Front Panel
29	1	9100-307	Shroud End Right Side Panel
30	1	9100-308	Shroud End Left Side Panel
31	1	9100-309	Shroud Back Panel
32	2	9100-310	Guide Rod
33	1	9100-311	Shroud Top Cover
34	2	9100-312	Extension Spring 1.375 x 1.75 x 28.28 L
35	1	9100-313	Weight Plate Decal 1-25
36	2	9100-314	Dampner Cylinder

ITEM	QTY	PART NO.	DESCRIPTION
37	4	9100-315	Dampner Safety Clip
38	2	9100-316	Handle Strap Grip Assembly
39	1	9100-317	Hinge .06 x 2.00 x 72.00 L
40	2	9100-318	Grip 5.88 L x 2.00 OD x 11 G
41	2	9100-343	Spring Cable Retainer Plate
42	2	9100-345	Pivot Shaft
43	1	9100-348	Spring Caution Decal
44	1	9100-598-1	Placard Decal
45	1	9100-598-2	Placard Decal
46	1	BH030201	Quick Release Pin .375 Dia. x 4.00 L
47	2	BR030206	Retaining Ring
48	4	BR030213	External Retaining Ring 2.00
49	4	BR030214	Retaining Ring .625 Dia.
50	4	BS070201	Spring .56 x .66 1.50 L
51			Removed
52	1	C-ZA000201	Half Weight
53	2	FB030213	Rod End Bearing .375-24
54	4	FB130206	Flange Bearing 2.00 ID x 2.25 OD x 1.00 L
55	4	FB130212	Flange Bushing Footplate .75 ID
56	2	GQ000206	Snap Link
57	2	HC702817	SHCS .375-16 x 1.00
58	4	HC702822	SHCS .375-16 x 1.50
59	56	HF589004	Panel Fastner #10-32 U
60	4	HF700000	Panel Fastner .375-16 U
61	56	HM581714	HHSS #10-32 x .625 Black Zinc
62	4	HN-60065	Hex Self Locking Nut .312-18 Black
63	19	HN-60560	Nylock Nut .375-16 Black
64	1	HN704000	Hex Nut .375-16
65	5	HN704400	Jam Nut .375-16
66	4	HN704901	Nylon Locknut .375-16
67	2	HN705618	Eye Socket Nut
68	1	PU060203	Bumper
69	2	HP286715	Pin .188 Dia x .75 Roll
70	1	HS308300	Split Lockwasher .250
71	2	HS407100	Spring Washer .650 ID x .790 OD x .062
72	4	HY662912	Set Screw .312-18 U x .50
73	4	HS-60531	BHSC .375-16 x .75 Black
74	11	HS-60535	BHSC .375-16 x 1.75 Black

**9100 - FT 360 Station**

ITEM	QTY	PART NO.	DESCRIPTION
75	10	HS-60536	BHSC .375-16 x 2.00 Black
76	2	HS-60534	BHSC .375-16 x 1.50 Black
77	10	HW-60085	Washer .3125 Black
78	4	HX-60184	Ball Stud .312-18 U x 10 mm
79	2	HX-60671	Plastic Cap 1.25 ID
80	1	JC620415	BHSCS .250-20 x .75
81	4	HC702815	SHCS .375-16 x .75
82	2	JN714400	Jam Nut .375-24
83	2	PP040002	Ball Stop
84	4	PP090202	Plastic Insert 1.50 x 3.00 x 11 G
85	2	PR060005	Weight Bumper
86	4	PP660009	Plastic Slot Insert
87	4	PR070003	Foot Pad 2.00 x 5.25
88	4	PR070004	Foot Pad 3.00 x 5.00
89	1	9100-60	FT-360 Arm and Stabilizer Assemblies
89 A	2	9100-201	Main Rotational Pivot
89 B	1	9100-202	Right Arm
89 C	1	9100-203	Left Arm
89 D	2	9100-207	Stabilizer Tube
90	1	59100	Owner's Manual (Not Shown)
91	1	54600	FT360 Training CD ROM (Not Shown)
92	1	9100-349	Front Panel Support
93	4	9100-353	Arm Celvis Spacer
94	2	PN149101	Snap Grip Hose Clamp
95	1	51198	Strength Warranty Sheet (Not Shown)

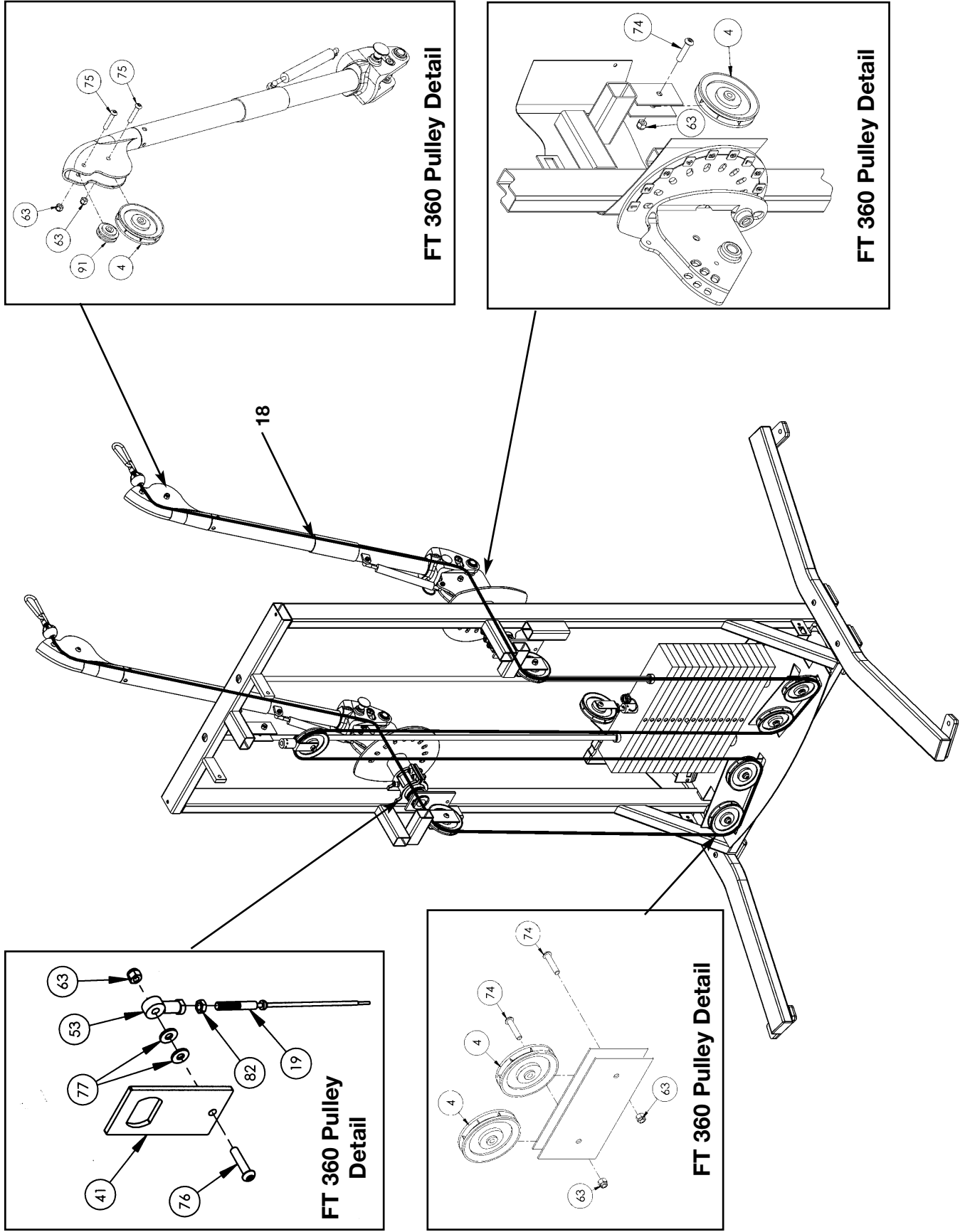

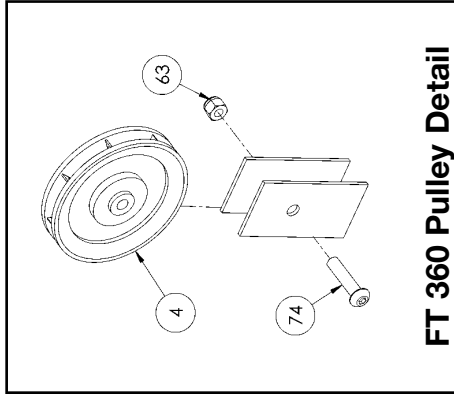
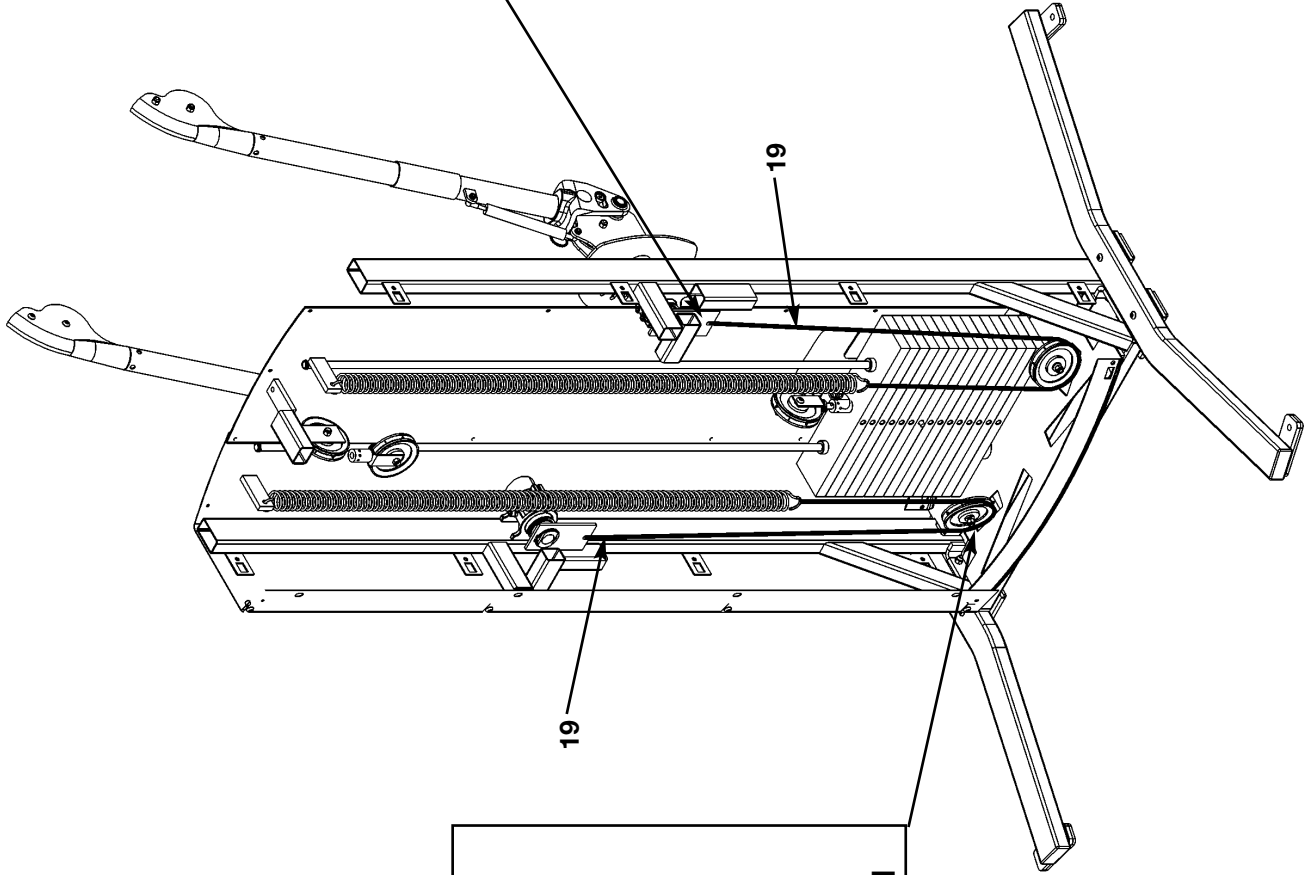
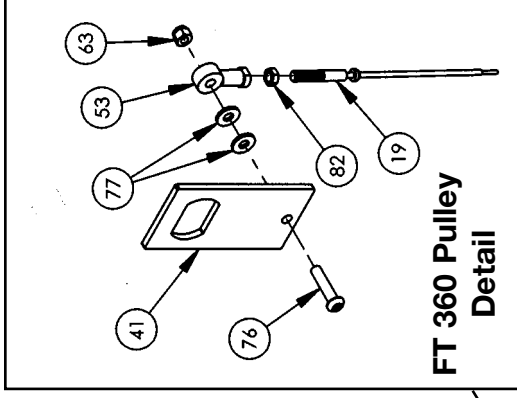

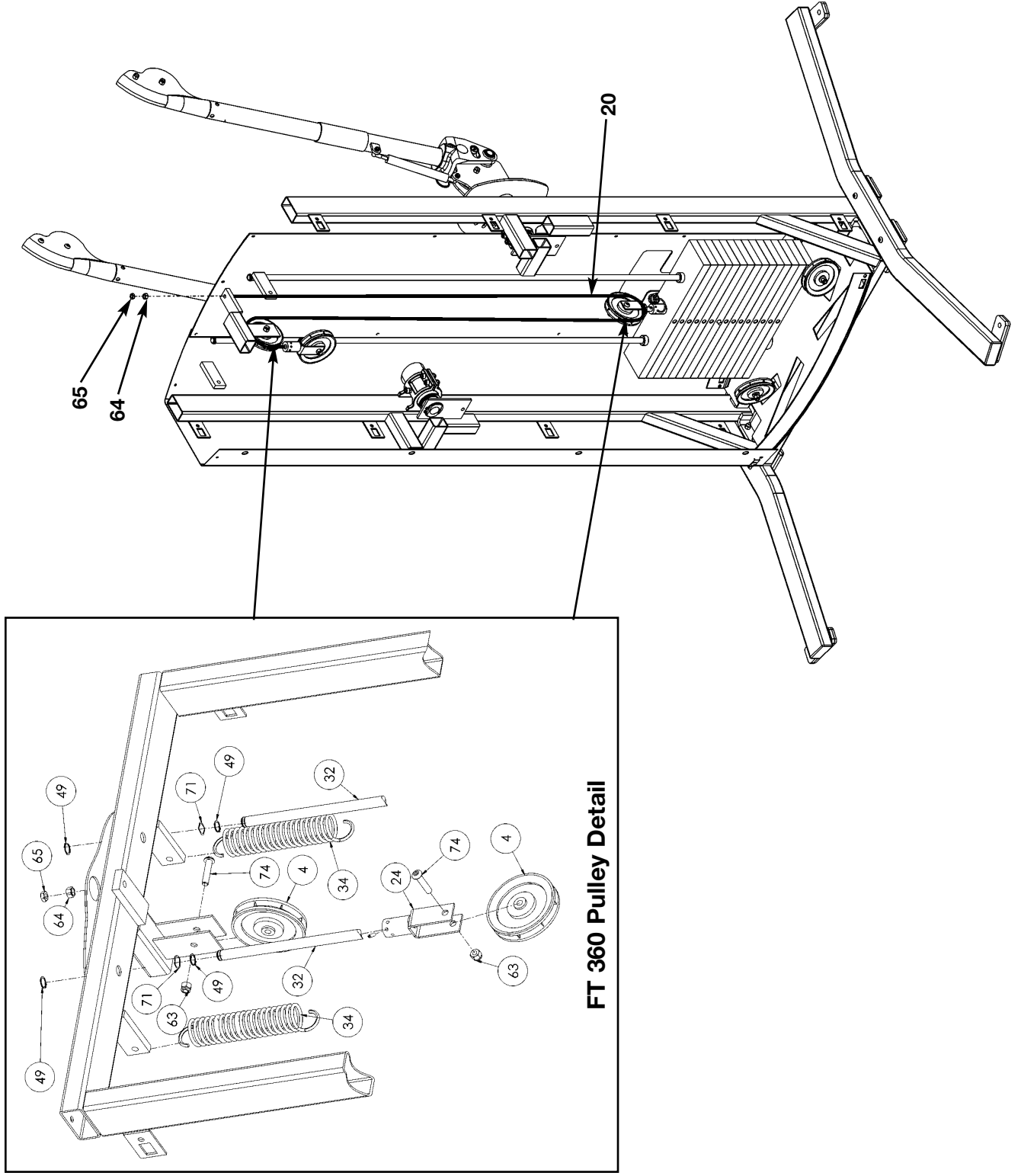









10 Trotter Drive Medway, MA 02053 • 508-533-4300 • FAX 508-533-5183  
www.cybexinternational.com • Techhelp@cybexintl.com • techpubs@cybexintl.com